


# Nordic Green Ammonia Powered Ships (NoGAPS)



Feasibility assessment of an ammonia-fueled gas carrier design

 **Nordic  
Innovation** Co-funded by Nordic Innovation

 **Mærsk Mc-Kinney Møller Center**  
for Zero Carbon Shipping

## Contents

Abbreviations.....	3	07 Machinery configurations.....	31
Acknowledgments.....	5	7.1 Power requirements .....	31
Executive Summary .....	6	7.2 Four-stroke machinery configuration .....	31
01 Introduction .....	8	7.3 Two-stroke machinery configuration.....	33
02 Design objectives and requirements .....	10	7.4 Assessment summary.....	35
03 Ammonia as a fuel.....	14	08 Other design considerations .....	37
04 Onboard vessel technologies .....	17	8.1 Fuel tank dimensioning .....	37
05 Rules and regulations .....	20	8.3 Stability.....	39
06 Accommodation location.....	22	09 Conclusions and next steps.....	41
6.1 Lifesaving appliances arrangement.....	23		
6.2 Ship motions and operability .....	24		
6.3 Assessment summary.....	29		



---

## Abbreviations

Acronym	Definition
2S	Two-stroke
4S	Four-stroke
ARMS	Ammonia release mitigation system
BLEVE	Boiling liquid expanding vapor explosion
CapEx	Capital expenditure
CFD	Computational fluid dynamics
CL	Centerline
CO <sub>2</sub>	Carbon dioxide
COG	Center of gravity
CPP	Controllable pitch propeller
DMA	Danish Maritime Authority
EGR	Exhaust gas recirculation
Ex	Explosion Hazardous area
FSM	Free surface moment
fwd	Forward
GHG	Greenhouse gas
GHS	Globally Harmonized System of Classification and Labelling of Chemicals
GM	Metacentric height
HAZID	Hazard identification
ICE	Internal combustion engine
IGC Code	International Gas Carrier Code
IGF Code	International Code of Safety for Ships Using Gases or Other Low Flashpoint Fuels
IM	Induction motor
IMO	International Maritime Organization
LOA	Length overall
LCB	Longitudinal center of buoyancy
LNG	Liquefied natural gas
LPG	Liquefied petroleum gas



Acronym	Definition
MGO	Marine gas oil
MMMCZCS	Mærsk Mc-Kinney Møller Center for Zero Carbon Shipping
N <sub>2</sub> O	Nitrous oxide
NoGAPS	Nordic Green Ammonia Powered Ships
NO <sub>x</sub>	Nitrogen oxides
PM	Permanent magnet
rpm	Revolutions per minute
SCC	Stress corrosion cracking
SCR	Selective catalytic reduction
SOLAS	International Convention for the Safety of Life at Sea
TSL	Temperature of superheat level
VFD	Variable frequency drive





## Acknowledgments

The Nordic Green Ammonia Powered Ships (NoGAPS) project is made possible by Nordic Innovation Fund funding and in-kind support from consortium partners, including:



Co-funded by: 

Flag Representative: 

Ship Designer: 

This report was developed by Thomas McKenney at the Mærsk Mc-Kinney Møller Center for Zero Carbon Shipping (MMMCZCS) based on a report by Breeze Ship Design for the feasibility phase of the NoGAPS 2 project.

Project consortium members include Marieke Beckmann (Global Maritime Forum), Anna Rosenberg (Global Maritime Forum), Joe Boyland (Global Maritime Forum), Thomas McKenney (MMMCZCS), Jun Kato (MMMCZCS), Koichi Sato (MMMCZCS), Martin Eriksen (MMMCZCS), Jun Ito (MMMCZCS), Peter Nerenst (MMMCZCS), Shinichi Iwamoto (MMMCZCS), Hiroyuki Yanagisawa (MMMCZCS), Ingvald Worren (Yara), Gunnhild Bækken (Yara), Hans-Henrik Ahrenst (BW Epic Kosan), Michael Kure Larsen (BW Epic Kosan), Dorthe Jacobsen (MAN Energy Solutions), Fredrik Lindfors (Wärtsilä), Harald Øverland (Wärtsilä), Pål Spilleth (DNV), and Magnus Jordahl (DNV).

Project steering committee members include Claus Winter Graugaard (MMMCZCS), Eystein Leren (Yara), Thomas Woidemann (BW Epic Kosan), Stefan Mayer (MAN Energy Solutions), Kent Åstrand (Wärtsilä), and Monika Johannessen (DNV).

We would like to thank members of our flag state representative, the Danish Maritime Authority, including Torsten Arnt Olsen, Karen Nissen Palm, and Rasmus Walther, and members of our ship designer, Breeze Ship Design, including Reinert Nordtveit, Sven Rolfsen, and Dmitriy Sonechko.



# Executive Summary

Ammonia is a promising alternative marine fuel. However, there are currently no ships capable of sailing on ammonia. The Nordic Green Ammonia-Powered Ships (NoGAPS) project brings together key players in the value chain to develop solutions for a Nordic-based, ammonia-powered, zero-emission ship. The first phase was publicly funded with private in-kind contributions, included members from across the value chain, and all results were made public. The second phase, which is currently in progress, uses public and private co-funding with a narrowing focus on the design, operation, and economics of an ammonia-fueled vessel. The M/S NoGAPS is a handy-sized ammonia-fueled gas carrier (22,000 m<sup>3</sup> cargo capacity) optimized for commercial operation in the North Atlantic and northwestern European waters.

NoGAPS 2, the second phase of the NoGAPS project, involves producing an initial ship design that will lay the foundation for a shipyard tender and the potential construction of the vessel. The Mærsk Mc-Kinney Møller Center for Zero Carbon Shipping (MMMCZCS) is leading the vessel design work for NoGAPS 2 in close collaboration with project partners and an external ship designer. The design follows an open innovation process to capture the best engineering practices around configuring the new design for ammonia fuel, best practices relating to safety standards and safeguards in design, energy efficiency, and choice of technologies. This report summarizes the results and findings from the feasibility assessment conducted as the first step of NoGAPS 2. The feasibility assessment identifies and evaluates ship design concepts that can achieve the design objectives and requirements. This high-level assessment is intended to evaluate the main design considerations, including the general arrangement and machinery configuration.

Design objectives for the M/S NoGAPS were defined based on conclusions from NoGAPS 1. The main objective of the NoGAPS 2 vessel design is to confirm that no major technical or regulatory obstacles are present. The design should also demonstrate a credible business model focusing on reducing risk and cost, while maintaining acceptable safety levels and fulfilling design requirements.

When using ammonia as a fuel, there are challenges, hazards, and opportunities that should be considered during the ship design process, including the properties of ammonia and their effects on human health and the environment, flammability, explosiveness, and corrosion. These considerations were incorporated in our feasibility assessment in addition to using DNV Rules and the IGC Code as the regulatory basis for the project. Close collaboration and discussion with class and flag administrations are also needed, as the IGC Code currently does not permit the use of cargoes identified as toxic products like ammonia to be used as fuel. There is an opportunity, however, to seek acceptance by the flag administration by justifying equivalent levels of safety by using a risk-based alternative design process.

Forward and aft accommodation locations were studied as part of the feasibility assessment, including the development of general conceptual arrangements. Our assessment of the accommodation location concepts concluded with selecting the aft accommodation solution. This was driven by the drawbacks associated with the forward accommodation location outweighing the benefit of lessened ammonia exposure to the crew at sea during an emergency. The NoGAPS team was also confident that a sufficiently safe design concept could be achieved with the aft accommodation location.

Two main machinery configurations were also assessed as part of the feasibility phase – an ammonia-electric propulsion system with four-stroke (4S) main engines and an ammonia-mechanical solution with a two-stroke (2S) main engine. Our assessment of the machinery configurations concluded with selecting the 2S option. This was mainly driven by the lower fuel consumption and reduced emissions for the 2S option. The 2S configuration also contributes to a simplified safety concept with a single ammonia consumer onboard that maximizes the emission reduction potential of ammonia as a fuel.

In addition to the two main design considerations for the feasibility phase related to accommodation location and machinery configuration, other design aspects were also evaluated, including fuel tank location and dimensioning, bunkering capability, and ship stability.



We have concluded that further studies on the vessel's bunkering capability, including installing a bow thruster, are needed as it presents a flexible option for the vessel's owner. Also, the main engine will be the only ammonia consumer with auxiliary engines and boiler, if needed, being fueled by conventional or biofuels.

The project has now entered the initial design phase to incorporate the key decisions and outcomes from the feasibility phase and increase the level of detail and analysis. This includes kicking off the initial design development, a hazard identification (HAZID) qualitative risk assessment workshop, optimization of vessel efficiency, submission of design drawings and documentation to target an approval in principle from DNV, and, finally, an initial design package that can be used for submission to shipyards for official tenders.

Ammonia-fueled engines, ammonia fuel supply systems, and emission abatement technologies are still in the early development stages. For the NoGAPS project, the design assumptions related to fuel consumption, pilot fuel amount and other performance-related values are to be considered expected or target values. As the design development progresses, continuous alignment with results from the technology and system development will be critical to ensure an optimal final ship design concept.

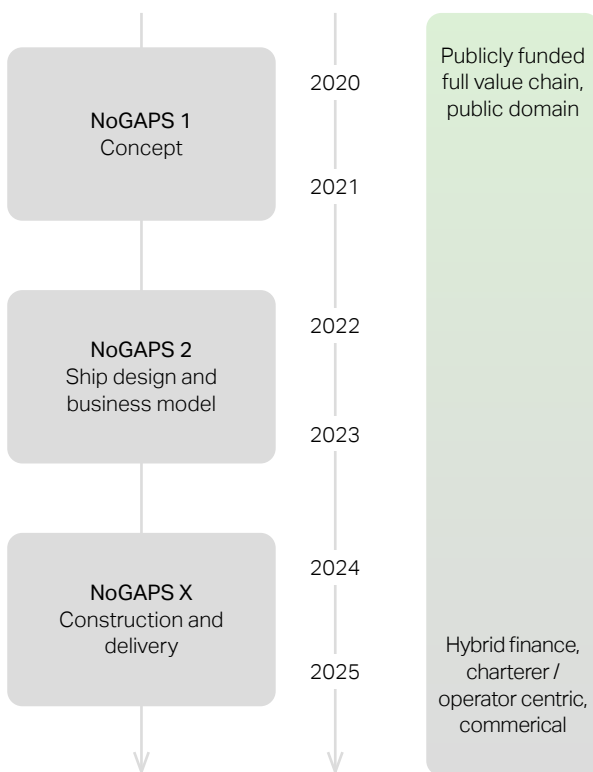


# 01 Introduction

Ammonia-powered shipping can make a credible contribution to the long-term decarbonization of the shipping sector.<sup>1</sup> Gas carriers offer an ideal opportunity to introduce ammonia-powered shipping early, as they already have relevant systems and crews that have experience with handling ammonia in a safe manner. As a result, the novel aspect of an ammonia-fueled gas carrier is limited to using ammonia as a fuel.

The Nordic Green Ammonia-Powered Ships (NoGAPS) project brings together key players in the value chain, developing solutions for Nordic-based ammonia-powered, zero-emission shipping. The NoGAPS project framework (Figure 1) covers bringing an ammonia-powered NoGAPS vessel from concept to reality.

Figure 1: NoGAPS project framework – from concept to reality.



The first phase of the NoGAPS project ran from 2020 to 2021 as part of the first round of the Sea Meets Land Mission, funded by the Nordic Innovation Fund. The project developed a holistic proof of concept that addresses ship design and safety, production, and supply of green ammonia, as well as the business models and economic incentives required to make the project economically viable.

The project developed a proof of concept on how the barriers to adopting ammonia as a zero-emission maritime fuel can be overcome, focusing on safety and efficiency, sustainable and steady fuel supply chains, as well as commercial viability. The results from NoGAPS 1 are available in a publicly available project report.<sup>2</sup>

In NoGAPS 2, the current project phase, we will produce an initial ship design, laying the foundation for a shipyard tender and potential vessel construction. This project brings together the essential players to source that design and is made possible by public and private co-funding from the Nordic Innovation Fund and in-kind support from partners. While NoGAPS 1 included stakeholders from across the value chain, this phase has a narrowed focus on the vessel and its design, operation, and economics. However, a broader interaction with the maritime ecosystem is still important to build support for the model and exchange knowledge during this phase.

In NoGAPS 2, the Mærsk Mc-Kinney Møller Center for Zero Carbon Shipping (MMMCZCS) is leading the vessel design work in close collaboration with project partners and an external ship designer in an open innovation process to capture the best engineering practices of configuring the new design for ammonia fuel, best practices of safety standards and safeguards in design, energy efficiency, and new choices of technologies. Ongoing work and our collective understanding of the risks associated with ammonia fuel storage, supply systems, and engine room design will be applied as part of a risk-based design process, including a HAZID to establish new guidance on safeguards and operational procedures. For example, the MMMCZCS is currently studying various aspects of ammonia safety including quantitative risk assessments and human factors.

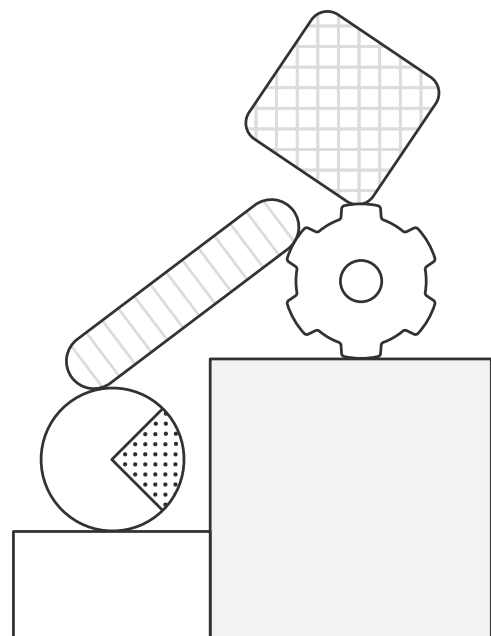
1 Maritime Decarbonization Strategy 2022: A decade of change, MMMCZCS, 2022.  
 2 <https://www.nordicinnovation.org/2021/nogaps-nordic-green-ammonia-powered-ship>



The main deliverable from the vessel design work will be an Approval in Principle by the designated classification society, DNV, in cooperation with NoGAPS partners and the Danish Maritime Authority (DMA). A design specification and drawing package will also be prepared for initiating a shipyard tender process and potential vessel construction.

After the completion of NoGAPS 2, future phases plan to focus on vessel construction and delivery. This will involve some public component (e.g., financing), but will primarily be defined by commercial agreements. There is currently no agreement in place for any future phases.

This report summarizes the results and findings from the feasibility assessment conducted as the first step of the NoGAPS 2 project. The feasibility assessment identifies and evaluates ship design concepts that can achieve the design objectives and requirements. This high-level assessment is intended to evaluate the main design and operational considerations for an ammonia-fueled NoGAPS vessel, including the general arrangement and machinery configuration.





## 02 Design objectives and requirements

We developed design objectives, requirements, and assumptions based on the outcomes from NoGAPS 1 as a starting point in the design process. This input was used as the basis for the feasibility assessment and the initial ship design phase.

The design objectives for NoGAPS 2 were defined based on conclusions from NoGAPS 1 (Figure 2). The first ship design-related objective is based on the conclusion that “neither the technical considerations nor the associated regulatory approval for an ammonia-powered vessel present major obstacles to putting the M/S NoGAPS on the water.” The NoGAPS 2 vessel design should confirm that there are no major technical or regulatory obstacles.

Figure 2: Main conclusions from NoGAPS 1 (Source: NoGAPS: Nordic Green Ammonia Powered Ship, Project Report, Nordic Innovation, 2021).

In line with the pillars of zero emission shipping, the consortium investigated the vessel, the fuel and the fueling options, as well as the business and financing considerations. The major conclusions were clear:

1. The potential of ammonia-powered shipping to contribute to the decarbonization of the maritime sector is significant, and ammonia carriers present a logical starting point for demonstrating this potential.
2. Neither the technical considerations nor the associated regulatory approval for an ammonia-powered vessel present major obstacles to putting the M/S NoGAPS on the water.
3. Ammonia synthesized from green hydrogen represents a credible long-term, zero-emission fuel.
4. The most important challenge to overcome is to develop and demonstrate a business model that is credible in the eyes of investors and operators. Both the vessel design and the fuel sourcing strategy offer opportunities to reduce risks and costs in meaningful ways.
5. Government support and public finance can both accelerate the short-term timetable for investment in demonstration and improve the outlook for long-term deployment of ammonia as a shipping fuel.

The second ship design-related objective is based on the conclusion that “the most important challenge to be overcome is to develop and demonstrate a business model that is credible in the eyes of investors and operators. Both the vessel design and the fuel sourcing strategy offer opportunities to reduce risks and costs in meaningful ways.” The NoGAPS 2 design should demonstrate a credible business model focusing on reducing risk and cost while maintaining acceptable safety levels and fulfilling design requirements.

The NoGAPS 2 design requirements are based on defined capabilities and particulars from NoGAPS 1. Some requirements are unique to ammonia-fueled vessels, while others are considered standard for this type of vessel. The main design requirements are:

### Cargo

- 22,000 m<sup>3</sup> cargo capacity
- Flexible design that can carry multiple gas cargoes, but the main intended cargo is ammonia
- Semi-refrigerated cargo tanks

### Operation

- Capable of operating with well-to-wake net-zero carbon equivalent emissions
- Optimized for commercial operation in North Atlantic and Northwestern European water
  - Intended route: Gulf of Mexico to Northern Europe
  - Range on ammonia: 12,000 nm with a four-day safety margin
  - Range on secondary fuel: 6,000 nm
  - Length overall (LOA) port restriction of 160 m
- Maximum service speed of 16 knots at design laden condition with a full load of ammonia (50% fuel and 50% utility)
  - An operational profile with 75% of the time at sea (average around 13.5 knots) and 25% of the time in port
  - Semi-refrigerated fuel tanks (8 bar, -33.2°C)
  - Crew complement includes 27, plus 6 Suez crew

### Ammonia bunkering capability

- Capable of being used as an ammonia bunker vessel to bunker other ammonia-fueled vessels
- Extra elevated manifold
- Increased maneuverability
- Fenders





## Rules & Regulations

- Class notation: 1A Tanker for liquefied gas, Shiptype 2G GF NH<sub>3</sub>, Clean design, E0, NAUT(OC), BMON, BIS, TMON, BWM (T), Recyclable, DNV Ice Class 1A

The M/S Yara Kara was defined as the reference vessel for the NoGAPS project. The Yara Kara is a trading ammonia gas carrier owned by YARA LPG Shipping A/S. The design of Yara Kara is conventional, with accommodation placed aft, a two-stroke slow-speed engine with direct drive to a controllable pitch propeller (CPP). No shaft generator is fitted. The ship is equipped with a bow thruster. The vessel is designed to use heavy fuel oil both in the main engine and the three auxiliary engines. This is possible due to the hybrid scrubber system serving all consumers.

If a requirement for the NoGAPS vessel design was not specified or defined, the Gas Form C for the reference vessel was used to define such a requirement or input. A Gas Form C is a proprietary form used by ship owners to document vessel characteristics and performance typically used as part of charter agreement negotiations. In addition to the reference vessel, where details are explained in a Gas Form C, other liquefied petroleum gas (LPG) carrier designs have been reviewed for inspiration and input in the design phase. The information available for these ships is limited, but some physical properties and main capacities such as cargo capacity, main dimensions, and installed power, are available.

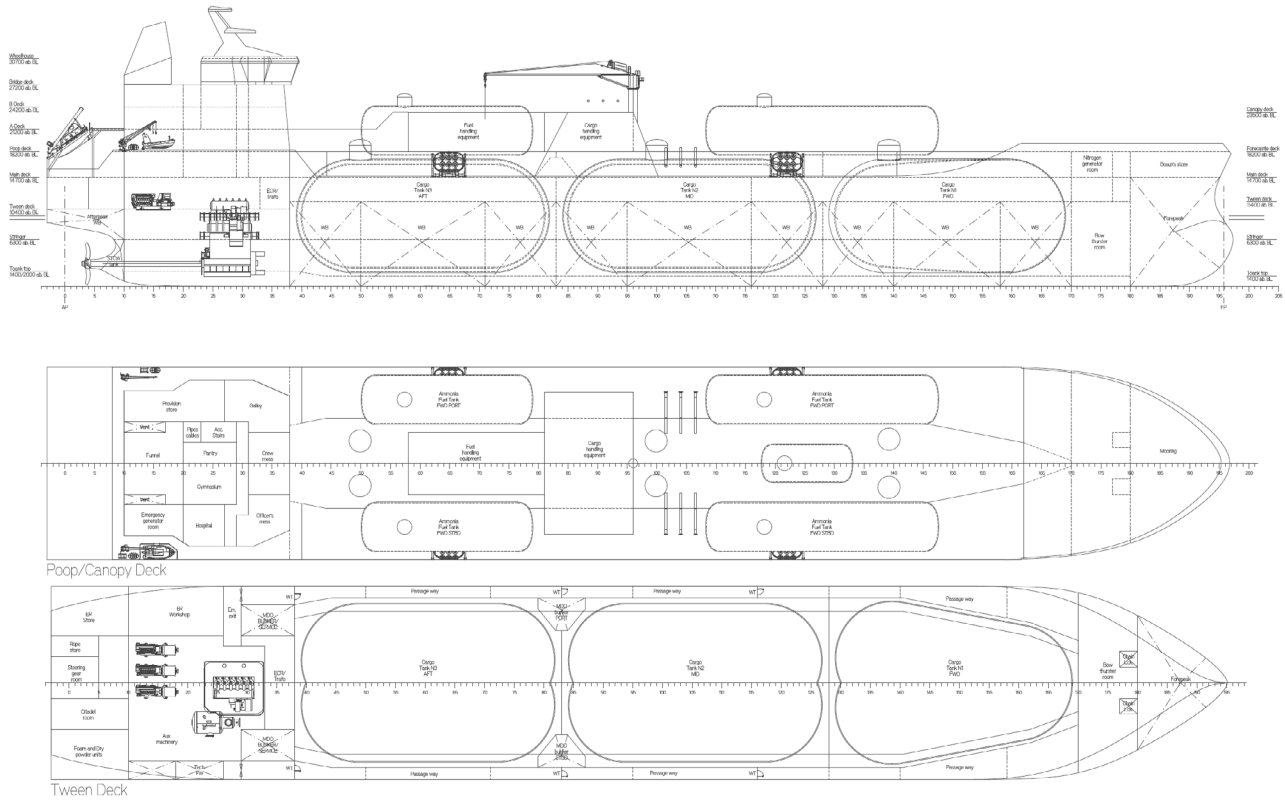
Four design concepts were defined as part of the feasibility assessment (Figure 4). These are based on different combinations of the accommodation location (either forward (fwd) or aft) and the main machinery configuration (two-stroke diesel-mechanical or four-stroke diesel-electric).

Figure 3: M/S Yara Kara (Source: Yara).

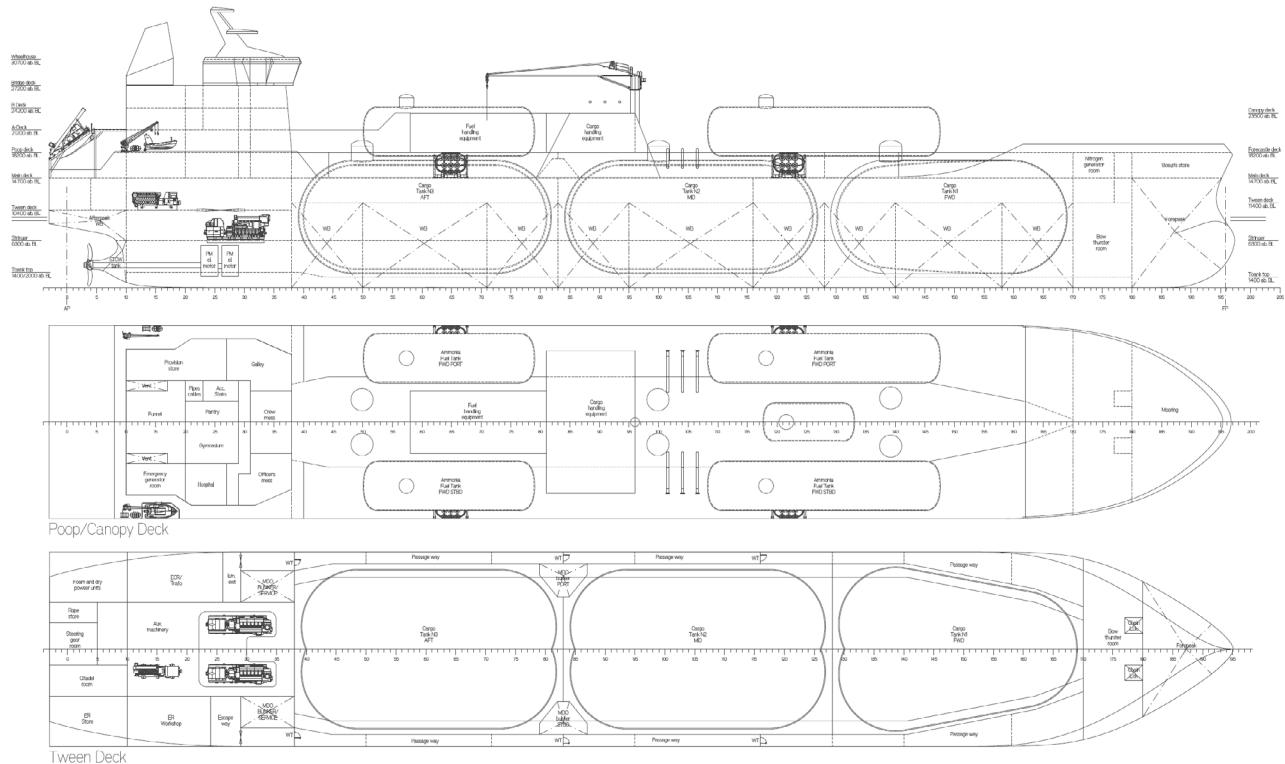


Figure 4: NoGAPS design concepts.

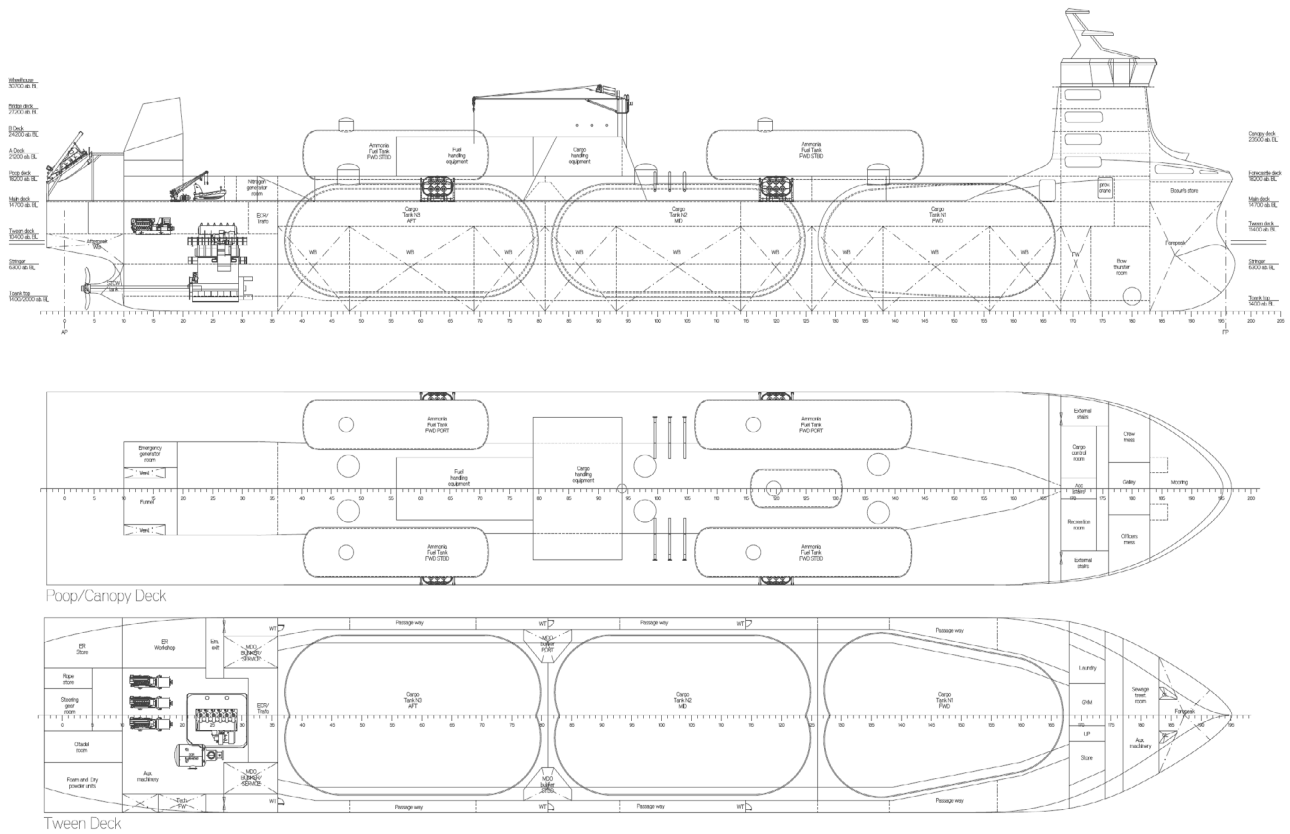
Aft accommodation, 2S machinery configuration



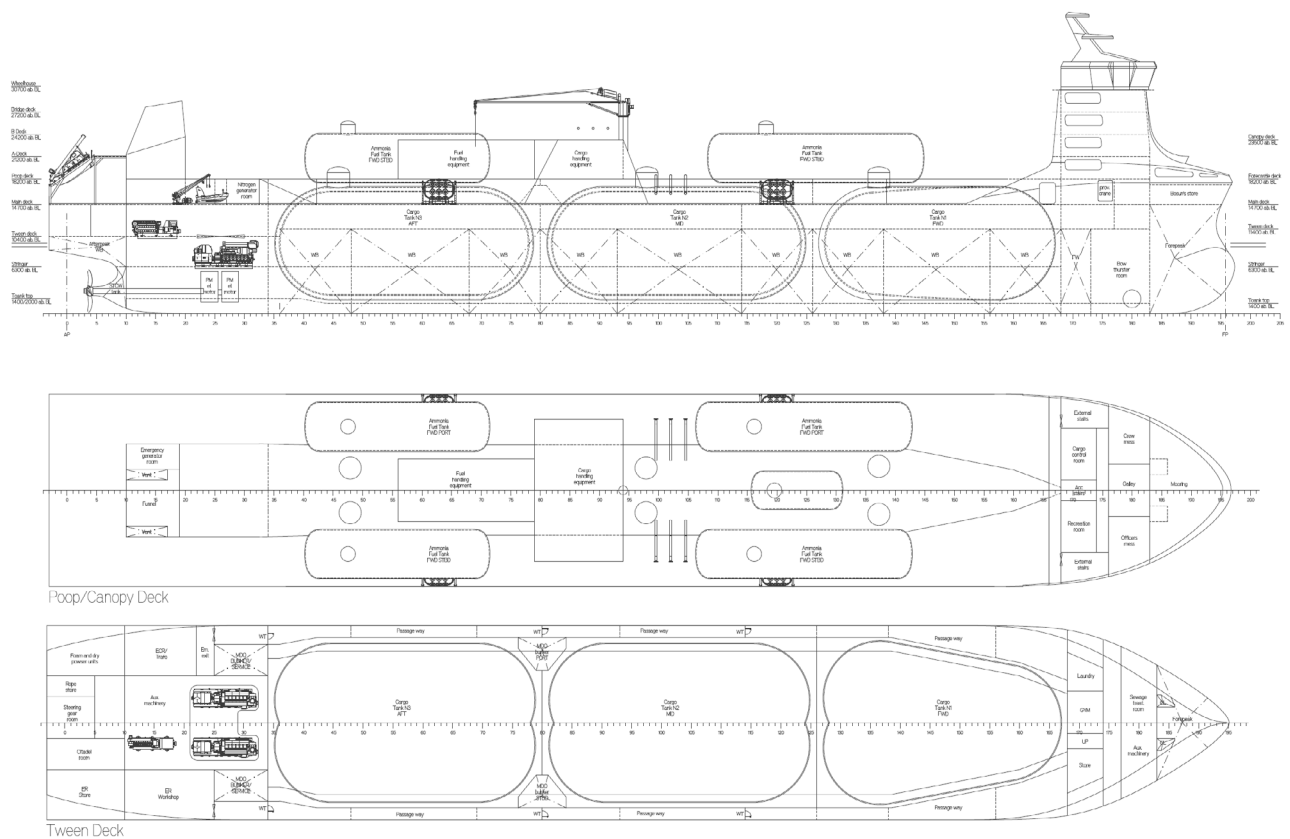
Aft accommodation, 4S machinery configuration



Fwd accommodation, 2S machinery configuration



Fwd accommodation, 4S machinery configuration



# 03 Ammonia as a fuel

When using ammonia as a fuel, challenges, hazards, and opportunities should be considered during the ship design process. This includes the properties of ammonia and its effects on human health (toxicity) and the environment, flammability, explosiveness, and corrosion.

## Properties

As a starting point, notable and relevant ammonia properties for ship design include:

- Boiling temperature of -33°C at atmospheric pressure.
- The vapor pressure at 45°C is 18 barA, and it can be stored as a liquid at ambient temperatures when pressurized.
- Temperature can be lower than -33°C in certain conditions and will freeze at -77°C.
- Denser than liquefied natural gas (LNG) and LPG.
- Flammable but hard to ignite.
- Alkaline and corrosive.
- Hygroscopic. Anhydrous ammonia readily absorbs water from the surroundings.
- Lighter than air in gaseous form, but cloud buoyancy is impacted by the liquid quantity airborne during the initial phase of the release. In addition, the ammonia cloud may absorb moisture from the air, increasing its density to become heavier than air.
- Dissolves easily in water in an exothermic reaction. Ammonia solubility decreases quickly with temperature, which needs to be considered as a limiting factor in ammonia absorption in water.
- Volumetric energy density in a liquid state is 65% of LNG and 35% of marine gas oil (MGO).<sup>3</sup>
- Slow flame speed.
- Care must be taken when handling spills/leakages due to the risk of cold burns.

## Effects on Human Health

Ammonia is a toxic substance. Acceptable human exposure limits to ammonia are defined by legislation and are typically a function of concentrations and exposure time. Examples of general effects of ammonia exposure at different vapor concentrations are shown in Table 1, which has been used as company guidance and for training.

Table 1: Ammonia exposure guidelines (Source: Yara).

Vapor concentration (ppm)	General effect	Exposure period
25	Smell detectable by most persons	Maximum for 8 hours working period
100	No adverse effect for average worker	Deliberate exposure for long period not permitted
400	Immediate nose and throat irritation	No serious effect after 30 min to 1 hour
700	Immediate eye irritation	No serious effect after 30 min to 1 hour
1,700	Convulsive coughing, severe eye, nose and throat irritation	Could be fatal after 30 min
2,000 to 5,000	Convulsive coughing, severe eye, nose and throat irritation	Could be fatal after 30 min
5,000 to 10,000	Respiratory spasm and rapid asphyxia	Fatal within minutes

<sup>3</sup> Source: MAN ES (Ammonia: 12.7 GJ/m<sup>3</sup>, LNG: 19.5 GJ/m<sup>3</sup>, MGO: 35.9 GJ/m<sup>3</sup>).



Acute exposure guideline levels have been extensively studied and documented as part of detailed reports, including from the National Research Council.<sup>4</sup> There is a significant difference between the concentration levels of ammonia at which it can be detected by smell and where exposure is hazardous to health. Therefore, injuries resulting from ammonia exposure are typically the result of large and sudden losses of containment. The exposure period is the critical factor in injury severity. Escape or sheltering-in-place philosophies are critical to emergency response planning for ammonia exposure.

Anhydrous ammonia is a hygroscopic compound, meaning it seeks water from the nearest source, including the human body. Anhydrous ammonia can dissolve body tissue, resulting in caustic burns. Because of their high moisture content, the eyes, lungs, and skin are at the greatest risk of caustic burns from ammonia.

## Effects on the Environment

From a safety point of view, drainage of ammonia spills overboard is preferable over retaining ammonia onboard. However, releasing ammonia into the sea will impact the environment and should only be considered in catastrophic scenarios, which should be extremely infrequent. Ammonia is classified as toxic to aquatic life, with the potential for long-lasting effects according to the Globally Harmonized System of Classification and Labelling of Chemicals (GHS).

Combustion of ammonia in an internal combustion engine (ICE) may generate nitrogen oxides ( $\text{NO}_x$ ), which is an air pollutant, and nitrous oxide ( $\text{N}_2\text{O}$ ), a potent greenhouse gas (GHG). It is assumed that existing selective catalytic reduction (SCR) technology can reduce  $\text{NO}_x$  emissions to compliant levels, and that ongoing engine and treatment technology development will be able to find solutions to manage  $\text{N}_2\text{O}$  emissions.<sup>5</sup>

## Flammability, Explosiveness and Corrosion

Compared with conventional fuels, ammonia's flammability range has a high lower explosive limit value of 15% volume and an upper explosive limit of 28% volume mixture in air. Methane and hydrogen start respectively at 5% and 4% volume mixture in air. Ammonia ignition energy is significantly higher. It can range in the literature from 8 mJ<sup>6</sup> up to 680 mJ.<sup>7</sup> Methane and hydrogen ignite at 0.3 and 0.015 mJ, respectively. Ammonia's auto-ignition temperature is over 650°C, around 100°C higher than methane and hydrogen. Due to the combination of these properties, ammonia burns poorly in open air and needs a supporting flame to keep burning. In confined spaces, ammonia constitutes an explosion risk, and it should be noted that oil contamination can increase the flammable properties of ammonia vapors.

When considering the above properties, it is expected that leak consequence modeling exercises will conclude with either limited or no need for hazardous zone definitions on open decks. In enclosed spaces, electrical equipment should be certified for use in Explosion Hazardous areas (Ex) Zone 1. In addition, proper ammonia detection with automatic process responses (main volume isolation) and an appropriate ventilation system must be considered.

A vapor cloud explosion can occur when a large amount of gas ignites in a confined or semi-enclosed space. The risk of fire and explosion exists exclusively in poorly ventilated rooms. Ammonia's minimum ignition energy is much higher than for other gases used for fuel, such as LNG. Thus, an ammonia release is hard to ignite. However, an explosion may occur if ammonia accumulates in a poorly ventilated area. Although ammonia is not highly flammable, containers of ammonia may explode when exposed to high heat due to its self-ignition properties. This is important to consider during ship design, and vessels must have systems that protect fuel tanks from nearby extreme heat sources such as fires.

4 Acute Exposure Guideline Levels for Selected Airborne Chemicals: Volume 6, Committee on Acute Exposure Guideline Levels, Committee on Toxicology, National Research Council, 2007 (<http://www.nap.edu/catalog/12018.html>)

5 Managing emissions from ammonia-fueled vessels, MMMCZCS, March 2023.

6 F.J. Verkamp, M.C. Hardin, J.R. Williams, Ammonia combustion properties and performance in gas-turbine burners, Symposium (International) on Combustion, Volume 11, Issue 1, 1967, pages 985-992.

7 Jarl N. Klüssmann, Ludvig R. Ekknud, Anders Ivarsson, Jesper Schramm, Ammonia Application in IC Engines, A Report from the Advanced Motor Fuels Technology Collaboration Programme by International Energy Agency, May 2020.



Ammonia is highly corrosive, reacting with various materials, including zinc, copper, and brass, rendering them unsuitable for use with ammonia. Various grades of carbon and stainless steel can be used with ammonia. However, carbon steels can experience stress corrosion cracking (SCC) when exposed to ammonia, and stainless steel could be subjected to brittle fracture in case of thermal shock. The fertilizer industry has gathered extensive knowledge about SCC, and today its degradation mechanism is well understood. The following preventive measures have been clearly defined and are widely applied to prevent SCC:

- Use stainless steel when feasible
- Perform post-heat treatment on welding parts to remove/reduce the stress in the material
- Develop operating procedures that minimize the possibility for oxygen to dissolve in liquid ammonia (focus on commissioning/recommissioning steps)
- Ensure that ammonia contains at least 0.2% of water (inhibiting the SCC process).<sup>8</sup>

Due to its high liquid-to-gas ratio (about 800), if cold liquid ammonia is introduced in a piping system filled with warm ammonia vapor, the rapid vapor condensation will create a short vacuum effect in the system. This will lead to a rapid change in the velocity of the flowing liquid, with the potential to cause catastrophic failure of piping, valves, and other components. This is called a hydraulic shock and must be considered early in the vessel design phase.

Another hazard associated with ammonia stored at pressurized conditions is flashing and expansion of ammonia when released into the atmosphere. Depending on the ambient conditions, in a warm climate above 20°C, pressurized liquid ammonia contains enough energy (heat) to instantaneously vaporize 20% of its volume, meaning that 20% of the ammonia will flash when leaving the tank. This sudden vaporization associated with this high liquid-to-gas ratio will lead to liquid carryover in the generated cloud.

In this condition, the release contains two phases, creating an aerosol, which will be heavier than air and travel at ground level until most of the tiny liquid ammonia droplets have been vaporized by ambient heat. The consequences are wider ammonia dispersion and extended risk contours.

When stored under atmospheric pressure at -33°C, ammonia will not display sudden vaporization behavior; the initial flash will be minimal, and the liquid quantity airborne will be reduced. The vaporization rate is driven by the heat input from the ground where the liquid will be spilled. Once cooled enough, the atmospheric condition and the evaporation surface will govern the vaporization rate. All this will contribute to significantly lower risk contours.

A boiling liquid expanding vapor explosion (BLEVE) is a physical explosion caused by immediate rapid boiling when a pressurized liquid, stored at temperatures well above its boiling point, loses pressure. For a BLEVE to occur, the liquid temperature when the pressure loss occurs must be above the temperature of superheat level (TSL). The TSL of ammonia is 89.8°C, much higher than ambient and storage temperatures. Therefore, if there is no abnormal heat (for example, from a fire in the vicinity), then ammonia BLEVE risk is limited.

---

<sup>8</sup> Water content of at least 0.2% includes margin, because measuring the dissolved oxygen in liquid ammonia can be difficult and preventing oxygen ingress is also a challenge.





## 04 Onboard vessel technologies

Transitioning to ammonia fuel requires the development of technologies that can use ammonia as a fuel, including fuel storage technologies, internal combustion engines, boilers, after-treatment technologies, and release mitigation systems. This section briefly introduces the different technologies considered for the NoGAPS project and their development status.

**Fuel storage:** Ammonia is a gas with a boiling point of  $-33^{\circ}\text{C}$  at atmospheric pressure. Its boiling point increases with increasing pressure, and at 18 bar, its boiling point is  $45^{\circ}\text{C}$ . That means ammonia can be stored as a liquid at ambient temperature and 18 bar. The main benefit of storing ammonia as a liquid is that the volumetric efficiency in terms of energy density increases compared to a gaseous state. For storage, the following options for transporting liquid ammonia are available:

- **Fully refrigerated:** At atmospheric pressure and  $-33^{\circ}\text{C}$ .
- **Semi-refrigerated:** At an elevated pressure between 1-18 bar and a temperature below the corresponding vapor temperature.
- **Fully pressurized:** In a pressurized tank that keeps the ammonia in a liquid state for the expected ambient temperatures (around 18 bar).

Choosing the appropriate storage method depends on the application. For smaller tanks, a fully pressurized tank is often preferable as there is no need for a reliquefaction plant to control the pressure build-up. The downside of a fully pressurized tank is that the weight of the tank will be high since the tank material has to withstand high pressures. The high pressures also favor a cylindrical, less space-efficient shape.

Semi-refrigerated tanks are pressure tanks designed for a lower design pressure than fully pressurized tanks. Because of the lower pressures, they require less material, saving on weight and cost. These tanks require a reliquefaction plant to control the ammonia vapor pressure, so it is kept well below the set point of the safety valves. The tanks still need a shape that supports increased pressures and typically have cylindrical characteristics. Still, tanks can be built with more space-efficient shapes than fully pressurized tanks.

Fully refrigerated tanks are intended for storing ammonia at atmospheric pressure and  $-33^{\circ}\text{C}$ . These tanks can be square, allowing for a volumetric-efficient design.

For the NoGAPS project, the design requirement was to have a semi-refrigerated system with Type C tanks for the cargo. The ship length limitation and cargo capacity requirement also meant that tanks for the ammonia fuel needed to be placed on deck. This also means that Type C tanks are required for the fuel. The main driver for selecting Type C cargo tanks is the flexibility to carry multiple cargoes with different storage requirements. If ammonia were the only cargo considered, alternative arrangements could have been considered.

**Internal combustion engine (ICE):** Engine makers MAN ES and Wärtsilä have been preparing and, in some cases, demonstrating ammonia-fueled engine operations using test engines in research laboratories during the period 2021 and 2022. Results from testing, including emission profiles, should be available during 2023, with the first engine deliveries expected in 2024.

The development of diesel engines from the beginning of the 1900s until now has involved continuous development with increasing efficiency, power output, service intervals, and reliability. The path for ammonia as fuel has just started, but ammonia-fueled ICEs are expected to build on the technology and experience from more conventional fuels such as diesel, LNG, and methanol. Like dual-fuel LNG and methanol ICEs, ammonia engines are being developed with two fuel systems (primary and secondary fuel) to ensure proper ammonia combustion, but also for redundancy purposes as the engines are also designed to be able to run on the secondary fuel only.

For the NoGAPS feasibility assessment, two- and four-stroke ammonia-fueled ICEs were considered. While the development of the first engines is expected to be completed in 2024, not all engine types and sizes will be available immediately. As a result, when developing one of the first ammonia-fueled vessels, one might consider matching the vessel design to the first engine types and sizes expected for delivery. Furthermore, vessel delivery may have to be adjusted to fit the engine development timeline for the required engine type and size.



**Boilers:** Most ships today are fitted with either an oil-fired or gas-fired boiler, depending on the fuel the ship uses. The boiler supplies heat for various ship needs. Depending on the ship type, the need for heat varies. Some ships have steam turbine propulsion, which means a boiler must produce all the steam that eventually will provide propulsion. Steam turbine propulsion is uncommon today, but many ships transport cargo that needs to be maintained at an elevated temperature. Due to heat loss, additional heat must be added continuously throughout the voyage. This can require the boilers to run continuously.

Other ships only have limited need for heat, or only periodical use of extensive heat. In these cases, it can be enough to use an exhaust gas economizer at sea or a periodical boiler to provide the necessary heat, for example in port. To meet stricter environmental legislation, boilers may also be required to burn ammonia to reduce GHG emissions. This is especially important if a substantial proportion of the ship's emissions come from boilers. Ammonia-fueled boilers are currently under development and are expected to be commercially available around the same time as ICEs.

**Exhaust gas after-treatment:** Engines and boilers produce exhaust gas, so exhaust gas after-treatment may be necessary. Although the reaction between ammonia and air does not produce carbon dioxide (CO<sub>2</sub>), it may produce NO<sub>x</sub>, N<sub>2</sub>O, and ammonia slip. The concentrations of these products in the exhaust must remain within desired or regulatory limits.

NO<sub>x</sub> is generated when nitrogen (originating from combustion air or ammonia) reacts with oxygen (from the air) under high temperatures during combustion in an engine or boiler. The International Maritime Organization (IMO) regulates NO<sub>x</sub> emissions from combustion engines, and ammonia-fueled ICEs must also comply with these regulations. Exhaust gas after-treatments for reducing NO<sub>x</sub> emissions are available and widely used today. They typically rely on SCR that reduces NO<sub>x</sub> to produce nitrogen and oxygen elements using aqueous urea. Exhaust gas recirculation (EGR) is also commercially available for NO<sub>x</sub> reduction for two-stroke engines.

N<sub>2</sub>O is not regulated by IMO today. However, N<sub>2</sub>O is a potent GHG that needs to be controlled. The introduction of ammonia as a fuel leads to the potentially higher risk of creating N<sub>2</sub>O, which must be monitored during the testing and development of ammonia-fueled engines, boilers, and fuel cells.

Unburned ammonia or ammonia slip may also be present in exhaust gases. The toxic and corrosive nature of ammonia released with the exhaust can harm people, the environment, and equipment. Various solutions are being investigated for handling ammonia slip. One is to rely on SCR, since the ammonia and NO<sub>x</sub> will react with each other in the same way as conventional SCR technology, where urea turns into ammonia that reacts with NO<sub>x</sub>.

The NoGAPS design incorporates SCR to manage NO<sub>x</sub>, with ammonia slip utilized as a reducing agent within the SCR. It is assumed that N<sub>2</sub>O emissions are reduced to near-zero levels using engine optimization.



**Ammonia release mitigation system (ARMS)** is intended to minimize the amount of ammonia released into the atmosphere, which is defined and required for vessels with a gas-fueled ammonia DNV class notation. The fuel system onboard such vessels must include an ARMS capable of collecting and handling ammonia from:

- Purging or draining fuel pipes
- Bleeding operations from double blocks and bleed arrangements on the fuel piping systems
- Releases from opening pressure relief valves on the fuel piping system
- Any other releases of ammonia occurring from normal operation of the system.

The ARMS must be capable of reducing the amount of ammonia discharged to air from the above operations to a concentration not exceeding 30 ppm. Discharges from the ARMS must be directed to a vent mast.

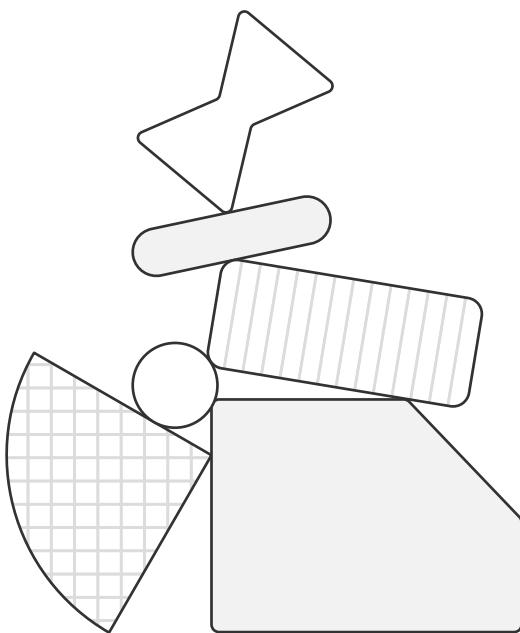
There are three main technical solutions for ARMS considered:

- Scrubber-type solutions
- Combustion-type solutions
- Reliquefaction

Scrubber-type solutions utilize the high solubility of ammonia in water. The ammonia from releases is injected, using a gas distributor/bubbler, into a vertical vessel filled with water or an acidic solution (e.g., citric acid). Nitrogen used in purging operations is not water soluble and can escape through the vent. Ammonia is retained in a solution for later safe disposal. The downside of this type of solution is a potential need for absorption media (e.g., citric acid), refilling, and disposal of the ammonia solution. However, this solution holds the key advantage that it is always ready.

Combustion-type solutions burn ammonia and utilize a flame sustained by pilot fuel. If fuel oil is used as the pilot fuel, then this type of equipment produces CO<sub>2</sub> as a byproduct; hence, efforts are being made to enable the use of ammonia as the pilot. In this case, however, as the ARMS system needs to be operational after an emergency shutdown, which includes cases where the fuel tank(s) will be separated, there is potentially a need to have a separate fuel source (e.g., ammonia bottles).

The third solution, reliquefaction, is the main technology onboard NoGAPS for handling ammonia vapor. However, a secondary ARMS system is required for the fuel supply system that can work independently of reliquefaction.



## 05 Rules and regulations

There are no ships using ammonia fuel in operation today. As a result, a prescriptive regulatory framework for designing and constructing a ship using ammonia as a fuel is not currently in place. A risk-based alternative design process must be used to achieve approvals for designs and construction until prescriptive rules are introduced.

The IMO regulates the safety for use of fuels through the International Convention for the Safety of Life at Sea (SOLAS). The regulations for conventional fuel oils are prescriptive and based on decades of experience. Utilizing fuels with a flashpoint below 60°C (defined as Low Flashpoint Fuels) has been prohibited to prevent tank explosions and fires. In 2015, the SOLAS Convention was amended to allow the use of low flashpoint fuels for ships complying with the International Code of Safety for Ships Using Gases or Other Low Flashpoint Fuels (IGF Code).

The IGF Code provides an international standard for the safety of ships using a low-flashpoint fuel. It was primarily developed to address the use of natural gas as fuel, but it does not prohibit other types of fuels. The IGF Code requires that the safety, reliability, and dependability of the systems shall be equivalent to that achieved by new and comparable conventional oil-fueled main and auxiliary machinery.

The IGF Code specifies a set of functional requirements applicable for all fuel types covered by the code, but only contains specific design requirements for LNG. Specific design requirements for other low-flashpoint fuels (such as ammonia) will be added as and when the IMO develops them. Until such regulations are in place, approval of ships using fuels other than LNG will be based on first-principal risk-based analysis demonstrating that the design complies with the basic functional requirements of the IGF Code. This risk-based approval process is referred to as the "alternative and/or equivalent design" approach, where an equivalent level of safety needs to be demonstrated.

The NoGAPS project will use the International Gas Carrier Code (IGC Code) as the regulatory design basis as it specifically applies to gas carriers, while the IGF Code applies to other ship types. Relevant parts of the IGF Code may be used for reference in cases where the IGC Code does not provide sufficient guidance or is inconclusive.

The IGC Code provides an international standard for the safe carriage of bulk-liquefied gases by sea. The IGC Code includes provisions allowing gas carriers to utilize cargo as fuel, which originated in the 1970s to utilize boil-off gas as fuel. Like the IGF Code, natural gas is the IGC Code's reference fuel. Other cargo gases are permitted, given that the same level of safety as natural gas is provided. However, the IGC Code does not permit the use of cargoes identified as toxic products like ammonia for this purpose. This means that the IGC Code, in its current form, does not permit gas tankers to use ammonia as a fuel. However, there are opportunities to seek acceptance by the flag administration by justifying equivalent levels of safety and complying with classification society guidelines for using ammonia as a fuel.

DNV has released the latest updates to its ship classification rules, with a range of new class notations designed to enable the maritime industry to address the decarbonization challenge and stay ahead of shipping's ever-tightening carbon-reduction requirements. The current updates include "Fuel Ready", a class notation that offers shipowners the option to prepare for later conversion to multiple alternative fuel options, and "Gas-fueled ammonia" for ammonia-fueled vessels.

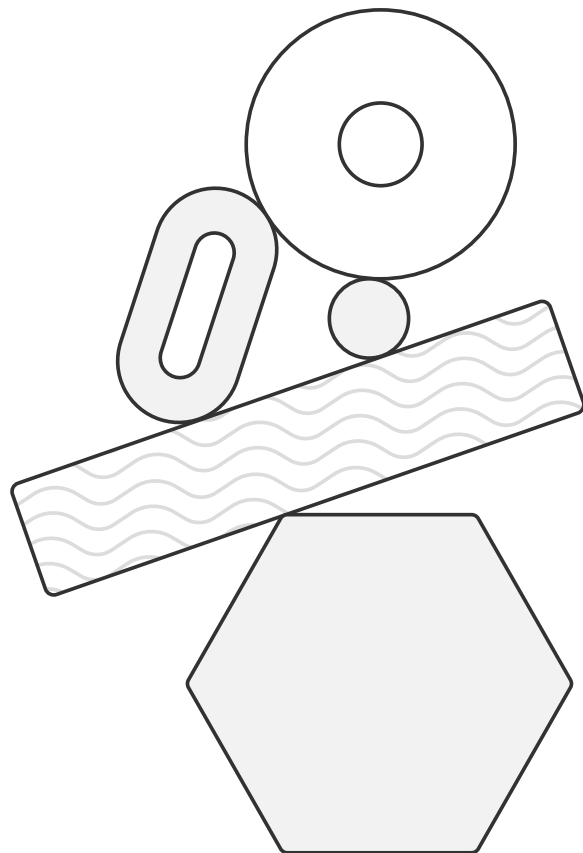
The required class notations for M/S NoGAPS include: 1A Tanker for liquefied Gas, Ship type 2G GF NH<sub>3</sub>, Clean design, EO, NAUT(OC), BMON, BIS, TMON, BWM (T), Recyclable, and DNV Ice Class 1A. In addition to notations associated with standard gas carriers and ammonia as a fuel, NoGAPS will obtain ice class designation as its operational profile will include Baltic operations in the winter.



The DMA Future Lab is the flag representative for the NoGAPS project. They will participate in evaluating the vessel's innovative zero-emission solutions and alternative ship concept arrangements and configurations, leading to authority review and target for approval.

IMO regulations for fire safety measures on tankers are also relevant for the NoGAPS vessel design project, with specific requirements related to:

- Separation of accommodation spaces from the remainder of the ship by thermal and structural boundaries
- Protection of means of escape
- Location of machinery spaces shall be positioned aft of the cargo tanks
- Accommodation spaces shall be positioned aft of the cargo tanks. However, accommodation spaces may be permitted forward of the cargo tanks subject to an equivalent standard of safety being provided to the satisfaction of the Flag Administration.



## 06 Accommodation location

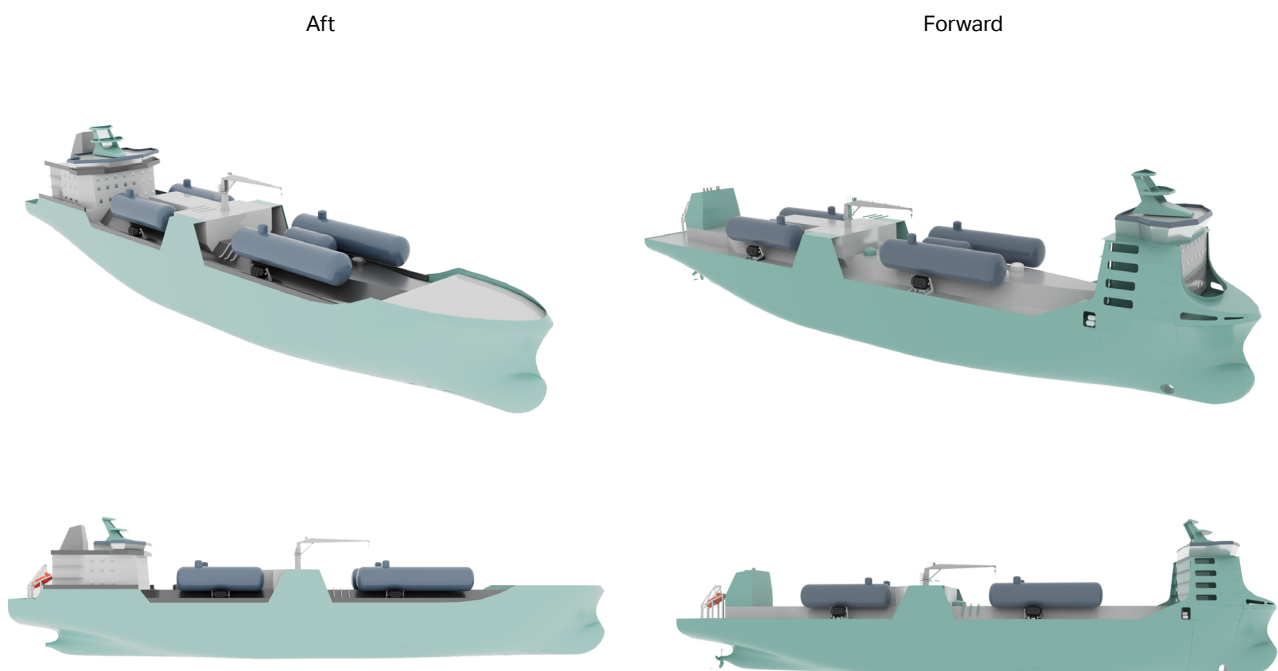
Forward and aft accommodation/deckhouse locations were studied as part of the feasibility assessment, including the development of general conceptual arrangements. The design process started with evaluating the space requirements for cargo and fuel, and then the accommodation and machinery were integrated. Consequently, the cargo section in all concepts is similar. This section will present the accommodation concepts and a summary of our evaluation criteria and decision-making process.

The main requirement for the accommodation block, regardless of location, is to accommodate 27 crew, plus six Suez crew. The ship's ice class notation and safety considerations make it reasonable to have enclosed bridge wings. Overall, the accommodation needs to follow good ship design practices in terms of practicality and efficient logistics on board. The deck layouts are provided in the general arrangements of the two accommodation variants in Figure 5.

The forward and aft accommodation options have some inherent differences. By having the accommodation forward, the available deck area for the accommodation is smaller than the aft alternative. This is because the accommodation cannot be placed on top of the cargo section, and the aft engine room requires the same longitudinal length regardless of accommodation placement. The result is that the forward accommodation block must be one deck higher than the aft alternative.

In addition to general arrangement differences, the lifesaving arrangement, ship motions, and operability were studied in more detail as main drivers of design concepts related to the accommodation location. Other aspects were considered as part of the final assessment and are detailed in the assessment summary.

Figure 5: Accommodation (deckhouse) location concepts.





## 6.1 Lifesaving appliances arrangement

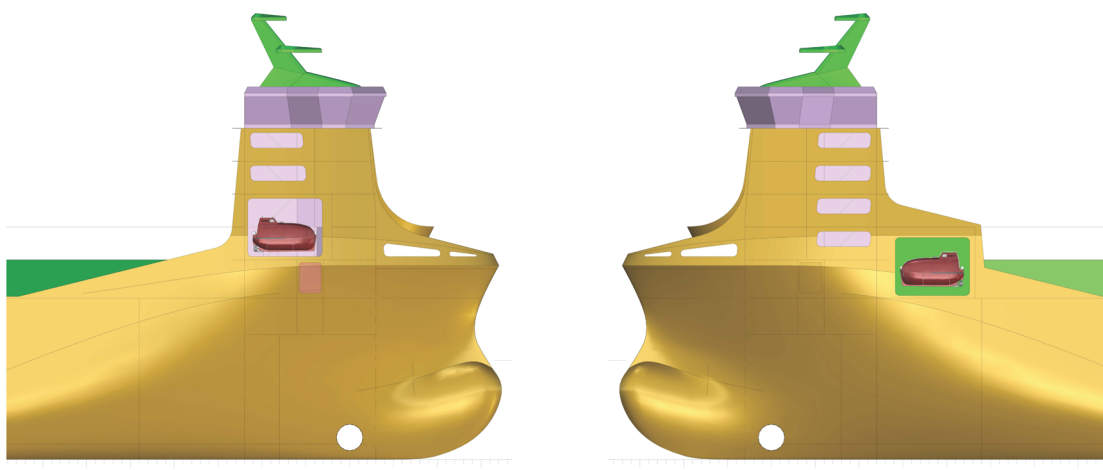
The type and location of the lifesaving appliances were central design drivers for the different accommodation locations, particularly for the forward accommodation option. The conventional lifesaving arrangement with an aft accommodation is to have one aft-facing free-fall lifeboat, and a rescue boat and rafts on the sides of the accommodation block. For the forward accommodation concept, the conventional lifesaving arrangement can be used as a basis, or side-launch lifeboats can be placed forward. Two side-launch lifeboat arrangements were studied (Figure 6). However, the second option was found to be non-compliant due to its location within the hazardous cargo zone.

The free-fall alternative is often deemed the most inherently safe option as there are fewer things to consider during launch. With side-launch lifeboats, there is a risk of them slamming against the hull if the ship is rolling, more preparation is needed by the crew during deployment, two release hooks need to be functional and released at the same time, and a davit with winches, brakes, and other hydraulic functions are needed for everything to work safely.

The downside with a free-fall lifeboat is that it must be placed on the aft of the ship for practical and regulatory reasons. If the accommodation is placed in the forward part of the ship and the lifeboat is in the aft, then the crew must transport themselves the length of the vessel to muster at the lifeboat. The situations that require the crew to muster at the lifeboat are always serious, and it can be because the ship's integrity is threatened. In the worst-case scenarios, the cargo section may be difficult to pass due to a fire or explosion. With forward accommodation and aft free-fall lifeboat arrangement, life rafts would be placed within the accommodation while the rescue boat would be placed in the aft.

After assessment of the lifesaving arrangement options for the forward accommodation option, it was decided that this design concept would include an aft free-fall lifeboat and rescue boat as well as life rafts within the forward accommodation.

Figure 6: Alternative lifesaving arrangements.



### Option 1:

- two (2) conventional lifeboats
- no additional rescue boat, thus 150% capacity each
- davit-launched
- non-hazardous area location

### Option 2:

- two (2) conventional lifeboats
- no additional rescue boat, thus 150% capacity each
- davit-launched
- hazardous area location



## 6.2 Ship motions and operability

Other important aspects to consider for the accommodation locations are operational efficiency and ship performance, including ship motions and operability. Impacts on crew comfort, trim, and stability are the most important considerations for accommodation location. Other aspects to consider include speed and cargo capacity.

The crew work and live onboard the ship for extended periods, and the working environment and living environment are comfortable to ensure a happy, rested, and motivated crew. Crew comfort is heavily influenced by ship motions (or motions in the area where the crew are located most of the time), noise, and vibrations. With accommodation forward, machinery and propulsion-related noise and vibrations are low for both machinery concepts. However, low-frequency vibrations from wave slamming will be worse with forward accommodation.

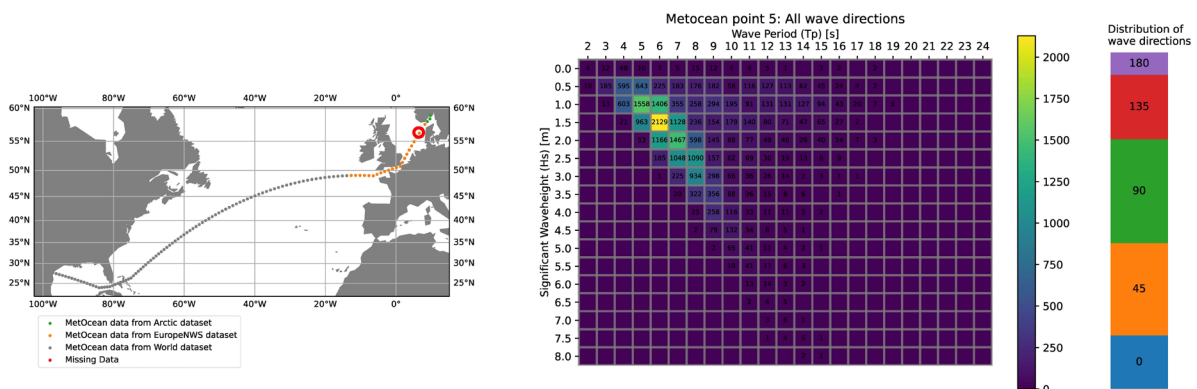
We conducted a seakeeping analysis to evaluate the ship's motions. Vertical acceleration, roll, and lateral acceleration were compared for forward and aft bridge positions.

For the analysis, we looked at the wave conditions at five locations en route from the Gulf of Mexico to Northern Europe (Figure 7). The color code in Figure 7 indicates the number of times a 3-hour sea state has occurred over the last seven years. The differences in ship motions were at points 23 and 50, since those were the locations with the highest sea states. The graph also indicates the direction of the sea relative to the ship's heading at this point on the route.

A ship motions analysis can be used to understand the hull response to the sea states as defined by the scatter diagram. The accelerations and motions at the defined point (bridge) are compared to a set of criteria defining maximum allowable values. For comparison reasons, we ran the analysis using two different sets of maximum allowable values to see the sensitivity of the ship's motions. A second reason for running two sets of analysis is that the standard values focus on the limit for when work can be performed safely, rather than comfort.

Ship motion criteria are based on values from NORDFORSK 1987. Table 2 provides the standard and strict motion criteria used for vertical and lateral accelerations as well as roll motion.<sup>9</sup>

Figure 7: Wave conditions on the planned route (Source: Metocean data from Wavefoil. Generated using E.U. Copernicus Marine Service Information).



<sup>9</sup> Ship motion criteria is based on values from "General Operability Limiting Criteria for Ships," NORDFORSK, 1987.



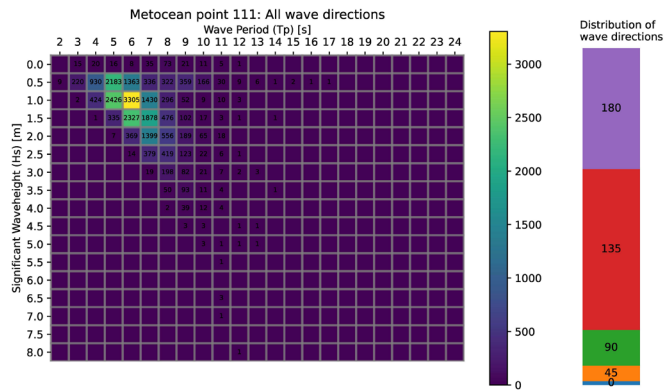
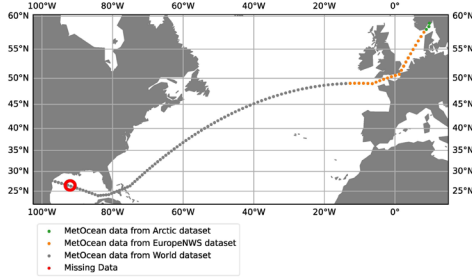
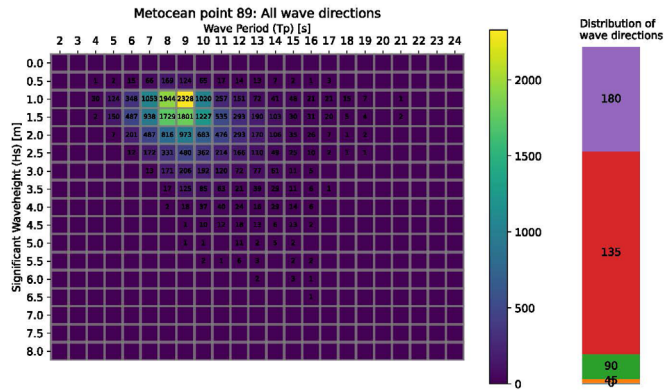
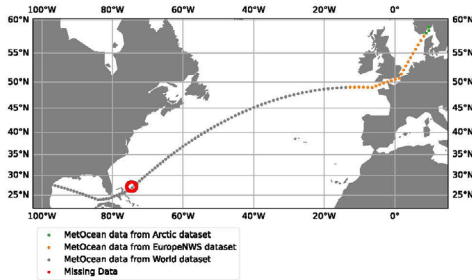
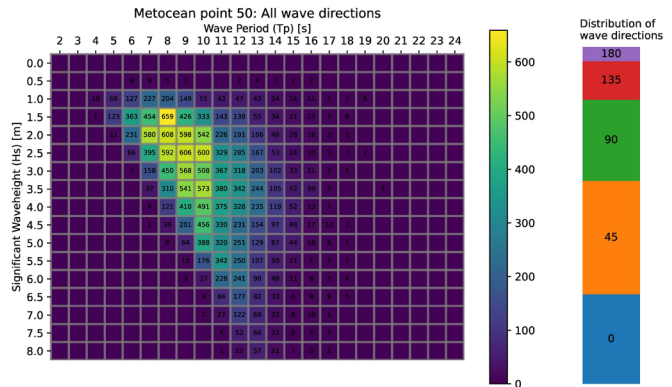
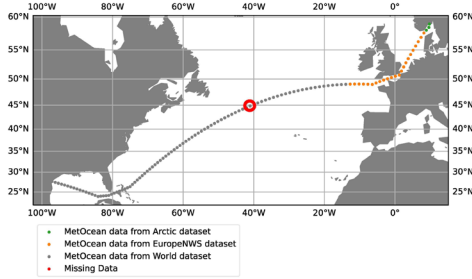
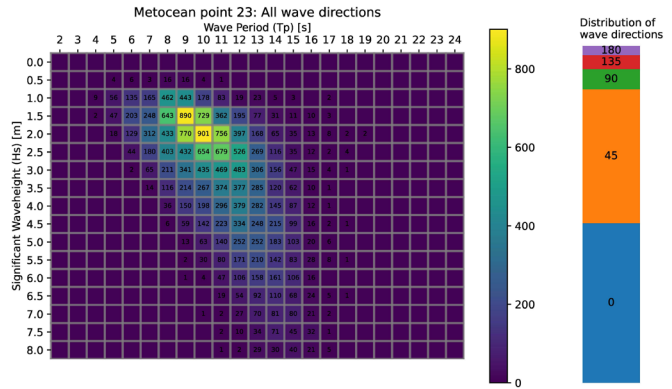
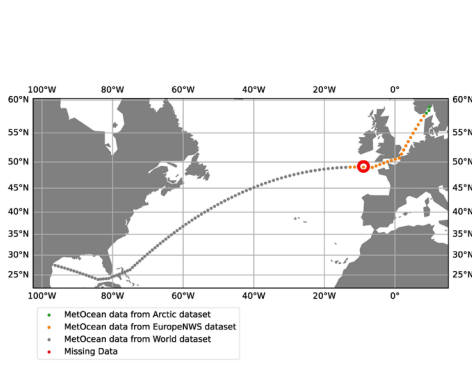


Table 2: Ship motion criteria (standard and strict).

	RMS Vertical accelerations	RMS Lateral accelerations	RMS Roll Mmotion
Strict motion criteria	0,01 G	0,05 G	3 degrees
Standard motion criteria	0,15 G	0,10 G	6 degrees

Based on the ship motions analysis and defined criteria, polar charts showing the percentage of operability were developed, showing vertical acceleration, lateral acceleration, and roll as a function of the relative wave direction (Figure 8). The numbers outside the circles 0–360 degrees indicate the wave angle relative to the ship. 180 degrees means following sea from aft. The numbers from 0 (center) to 100 (outer circle) indicate the percentage of operability time at that angle of sea, which is determined based on the ship motion criteria.

Vertical accelerations were the main criterion when evaluating operability, as they differed based on the accommodation location. Lateral accelerations and roll were similar for both accommodation locations and were not considered when evaluating operability.

In ballast condition, there is a significant difference between forward and aft accommodation on the operability when considering vertical accelerations. Lower operability was calculated for forward accommodation during head to beam seas: 65-70% operability for forward accommodation and 90-95% for aft accommodation. When the ship is in ballast condition westbound, it is typically sea with directions from head to beam across the Atlantic Ocean.

In loaded condition, lower vertical accelerations were calculated. A slightly higher operability for aft accommodation was observed for head to beam seas. In the loaded condition eastbound, there will typically

be following to beam seas, where the performance between the two accommodation locations is similar. Placement of accommodation had an impact on vertical accelerations in the accommodation spaces, with large differences observed in some sea states and headings. We foresee that a vessel with forward accommodation will have to reduce speed more often than a vessel with aft accommodation to maintain acceptable conditions onboard. Hence, forward accommodation is the least preferable option in this regard. Operational observations from vessels with forward accommodation also confirm that speed reductions are sometimes necessary in higher sea states from certain directions.

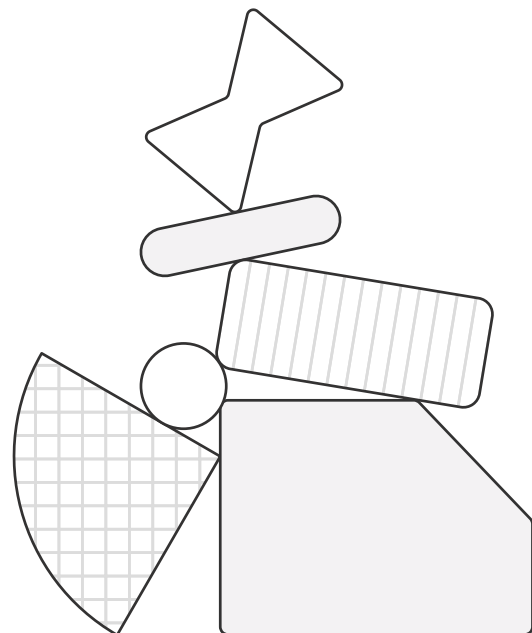
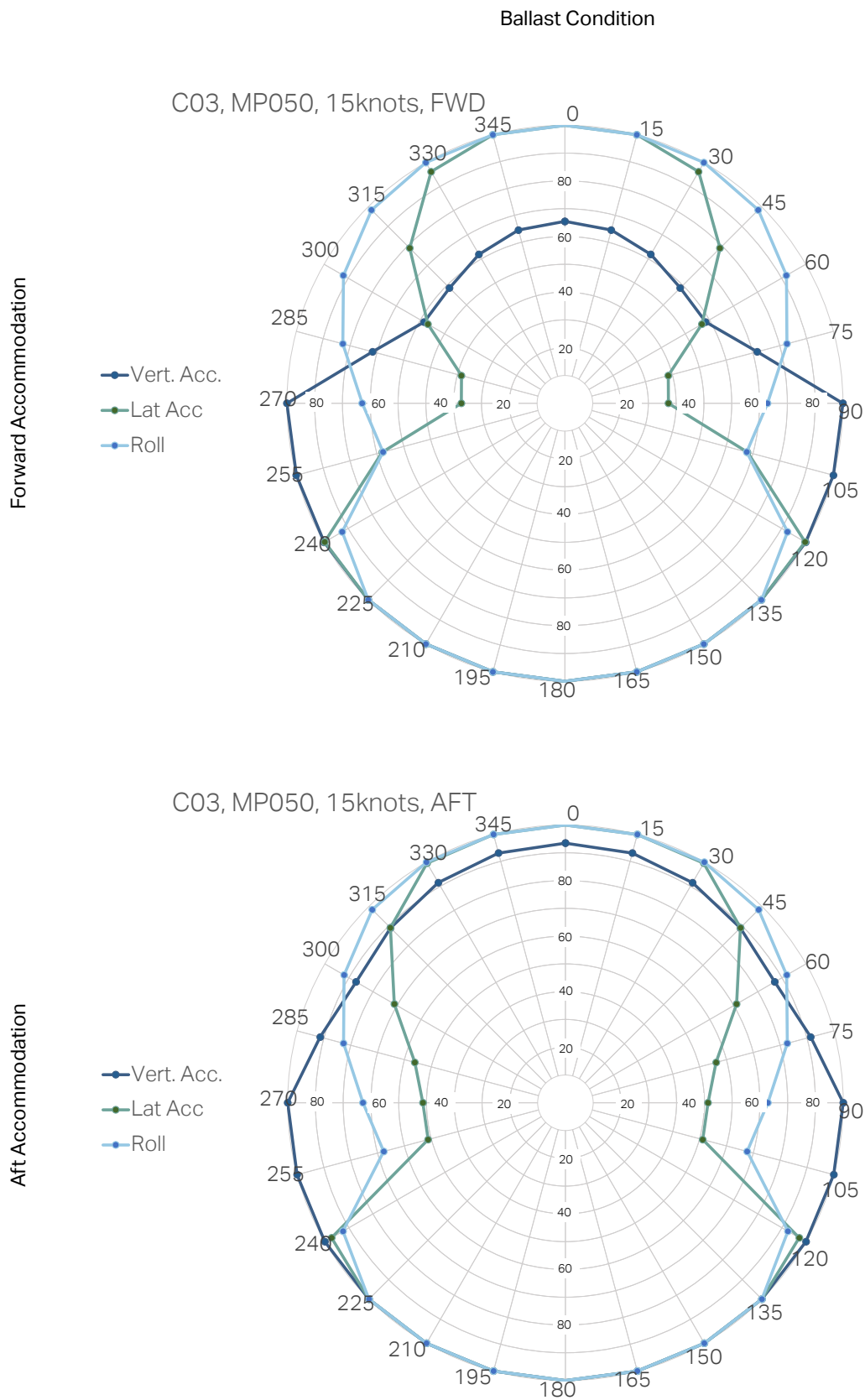


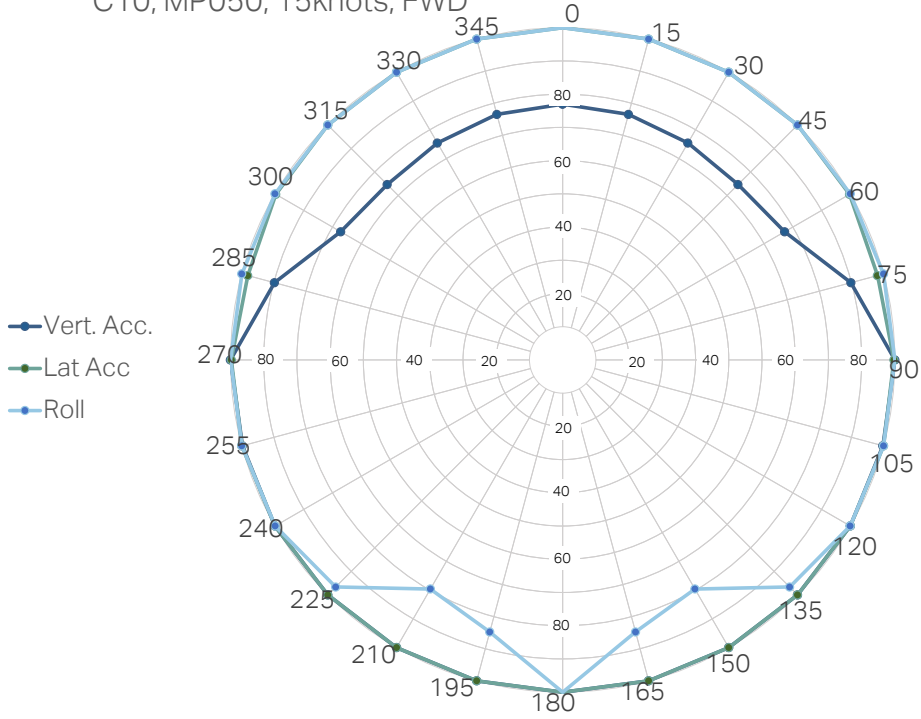
Figure 8: Operability assessment results (ship motions and accelerations).



Loaded condition

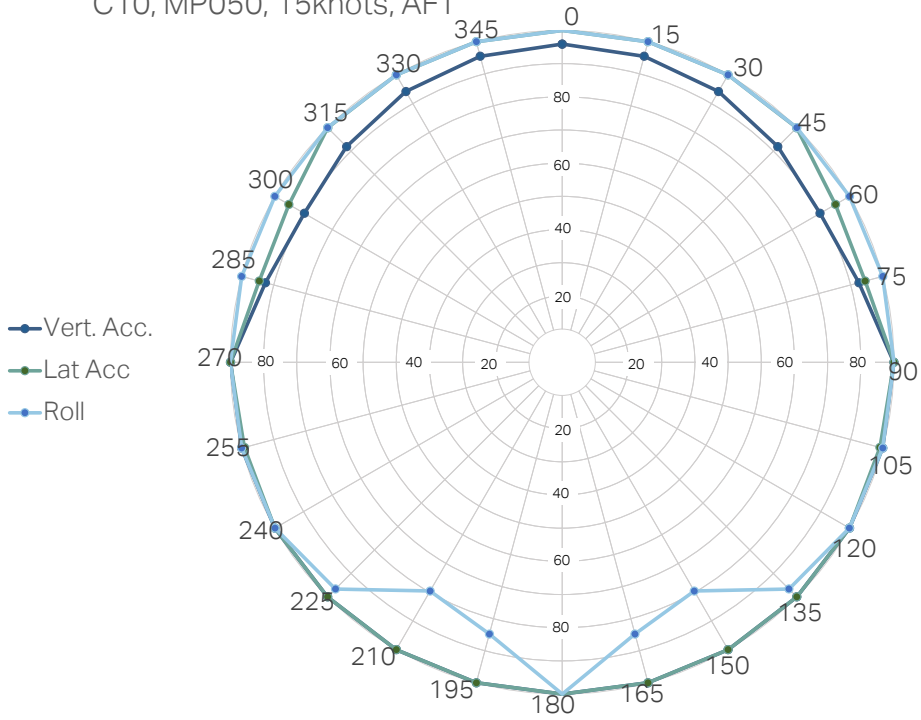
Forward Accommodation

C10, MP050, 15knots, FWD



Aft Accommodation

C10, MP050, 15knots, AFT





### 6.3 Assessment summary

This section summarizes our assessment of the accommodation location options, which was done independently from machinery configuration assessments. In addition to the two considerations already presented, including the lifesaving arrangement and ship motions and operability, other considerations included safety and operations, cost, commercial availability, and design complexity. A summary of our assessment is provided in Figure 9. In terms of importance, emphasis was placed on safety and comfort.

The accommodation aft is the conventional setup for this type of ship. As mentioned earlier, due to the allowed larger footprint of the accommodation, the height could be one deck less than the forward accommodation alternative. This solution makes for a more compact arrangement in the aft part of the ship, with the exhaust funnel, rescue boat, free-fall lifeboat, and provision crane all placed in the aft part next to the accommodation.

Various safety aspects were considered. One aspect was potential exposure due to leaks from the cargo, fuel tanks, or ammonia-fueled machinery. Exposure to leaks can come in many forms. The cargo section of the ship will be conventional and comparable to the LPG carriers seen today. Most other LPG carriers have accommodation aft and, thus, this is considered a safe design. The chances for leakage in the cargo system are expected to be greatest during cargo operations when the ship is in port. In this case, the most beneficial solution is accommodation aft since only one wind direction would lead to entry into staffed areas. With accommodation forward, two wind directions can blow leakages into staffed areas: the engine room aft and accommodation forward.

The ammonia fuel system is the novel aspect of the M/S NoGAPS. The fuel system will be built with the same requirement in terms of safety as cargo piping. However, the fuel system has higher pressures and is exposed to vibrating engines, so the risk of leakages in this system is higher. The fuel handling and treatment system will be placed in a deck house, and ventilation from this space will be arranged.

Figure 9: Accommodation location assessment summary.



Here, the chance for leakage is greatest during sea passage, when the ammonia consumers are in use. The relative wind direction while at sea is typically towards the aft, which would result in leakages from the fuel handling room and connected ventilation exhaust to go towards the aft accommodation area.

The solution with accommodation forward makes managing potential leakages or releases at sea easier through an inherently safe design. Fewer people could be exposed to leakages, both from cargo area vent masts and engine room-related equipment. Inherently safe solutions are good because they do not rely on all other safety measures to work for them to be functional. Many safety features include ventilation, detection, doors, valves, shutdowns, etc., which must all work to provide the intended level of safety. For leakages occurring in the engine room, it is also beneficial with the accommodation forward since this creates a completely segregated area where most of the crew are located. Keeping an aft accommodation solution safe relies on active measures such as doors being closed, ventilation working as intended, sensors detecting leaks quickly, valves closing ammonia supply, and engines switching over to conventional fuel.

There are many safety risks on a ship besides fuel or cargo leakage. Groundings, fires, and other incidents need distinct types of responses. Mustering for firefighting, man overboard, abandoning ship, emergency operation of steering gear and pitch, response to engine room alarms, and fighting piracy need to be considered when evaluating the accommodation placement. A forward accommodation solution has disadvantages in all these operations.

The costs of accommodation placement mostly concern ship production. Accommodation forward introduces some additional costs that should be evaluated. Forward accommodation will require additional piping and cabling running along the ship between engine room power distribution and accommodation consumers. In addition, forward accommodation incorporates side and bow plating with more shaping compared to the more flat shape of the aft accommodation solution. With forward accommodation, indoor walkways must also be built along both sides of the ship to enable safe access to the free-fall lifeboat and engine room, even in bad weather. All these elements introduce additional costs compared to the aft accommodation alternative.

Design complexity has a relatively small impact on the selection of the accommodation location. However, ship designers may have limited experience with accommodation forward on LPG carriers, given the small number of ships built with this solution. Consequently, it can be difficult to know the impact on seakeeping performance, cost, safety, and practicality to the fullest extent.

Commercial availability may become relevant and impact the overall building cost of the ship. Ships with custom designs can introduce a higher risk for shipyards, and that risk is often translated to higher building costs compared with building conventional designs.

In summary, our assessment of the accommodation location concepts concluded with the selection of the aft accommodation. This was driven by the multitude of drawbacks outweighing the benefit of potential ammonia exposure at sea for the forward accommodation option. The NoGAPS team was also confident that a sufficiently safe design concept could be achieved with the aft accommodation location.



## 07 Machinery configurations

We assessed two machinery configuration concepts as part of the feasibility phase: an ammonia-electric propulsion system with four-stroke (4S) main engines and an ammonia-mechanical solution with a two-stroke (2S) main engine. Both solutions drive a controllable pitch propeller (CPP). The reason for selecting a CPP is the improved maneuverability and better performance in ice (higher thrust at low ship speeds). A fixed-pitch propeller gives slightly better propeller efficiency (1-2%) at the design point. As the M/S NoGAPS will have an ice class designation, variable trading pattern, and potential to function as a bunkering vessel, we selected the CPP.

The following sections detail the vessel's power requirements, the two machinery configurations, including fuel consumption calculations, and a summary of our evaluation criteria and decision-making process. Ammonia-fueled engines and ammonia fuel supply systems are still in the early development stages. For the NoGAPS project, the design assumptions related to fuel consumption, pilot fuel amount and other performance-related values are to be considered expected or target values.

### 7.1 Power requirements

Fuel consumption calculations have been made for both machinery configurations to evaluate their performance and emissions for the defined operational profile. To dimension the prime movers, calm water resistance was considered with a 15% sea margin. Speed power curves for the two machinery configurations were developed based on laden and ballast conditions.

For the 4S options, a 5% higher propeller efficiency/reduced shaft power has been assumed due to the freedom to operate at different revolutions per minute (rpm) with this solution and the reduced need to include propeller margin. This assumption is difficult to predict accurately at this stage of the design process, but is important to capture when calculating power requirements. In addition to propulsion power demand, the ice class power requirements and hotel loads were also calculated and included in the fuel consumption calculations.

### 7.2 Four-stroke machinery configuration

The 4S diesel-electric configuration includes two main ammonia-fueled generator sets (3,360 kW each): one that will be required to run while the ship is at service speed, and one smaller diesel/biofuel-fueled generator set (1600 kW) that can provide electrical energy while the ship is in port. The main driver of selecting a third generator set was to provide a capital expenditure (CapEx)-friendly source of system redundancy that also has better port load efficiency. It is also possible to use a shore power connection for the power needed in port.

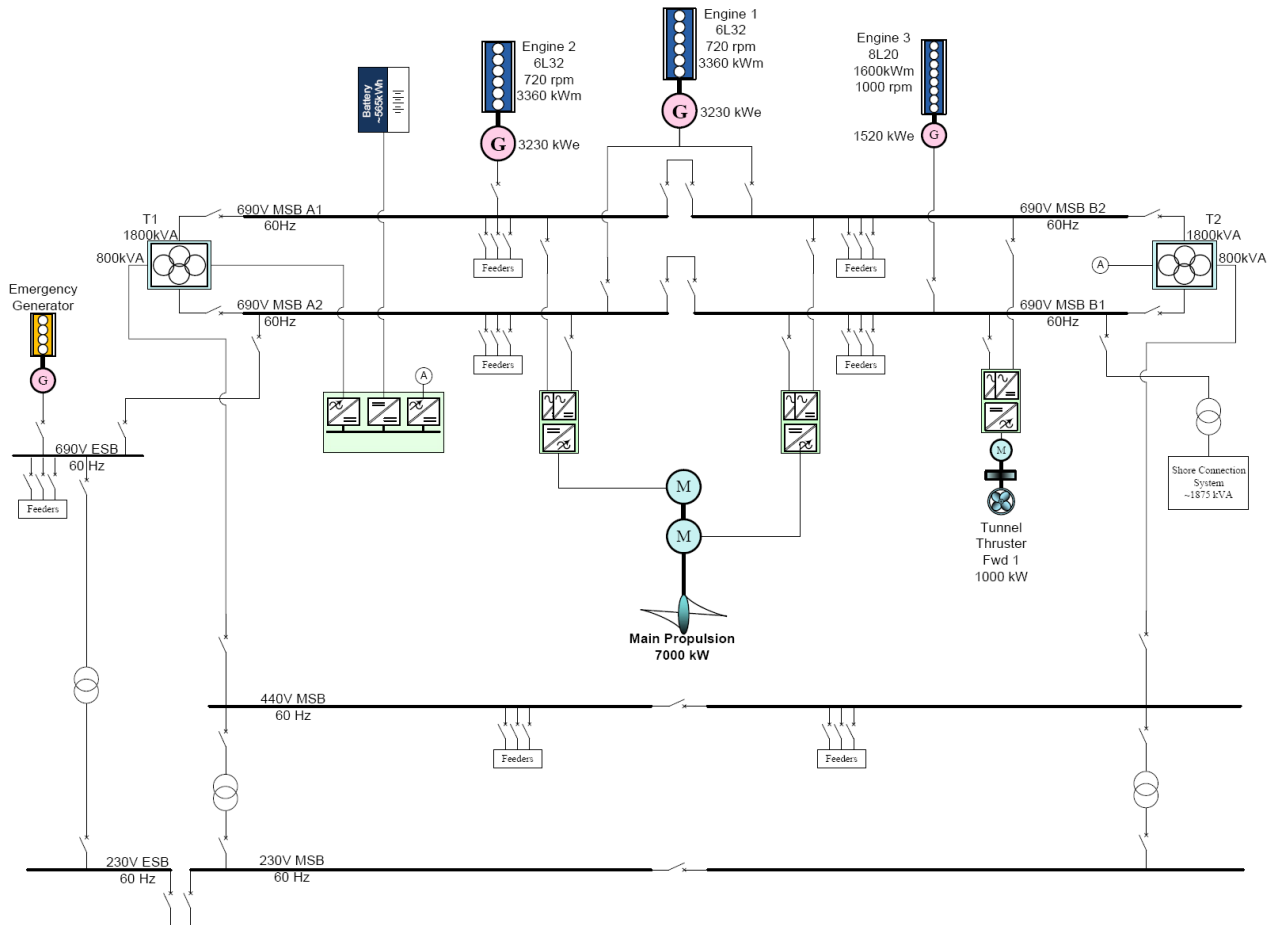
Four different 4S configurations were initially investigated. The main difference between these four options is the type of electric propulsion motors used and if a gearbox is required. These solutions have different costs and efficiencies. The four options include:

- 4S IM1: 2 induction motors (500 rpm) in parallel connected to a twin input step down gearbox driving a single output propeller shaft + battery.
- 4S IM2: 2 induction motors (500 rpm) in parallel connected to a twin input step down gearbox driving a single output propeller shaft.
- 4S PM1: 2 permanent magnets (80 rpm) in tandem, directly driving the propeller shaft + battery.
- 4S PM2: 2 permanent magnets (80 rpm) in tandem, directly driving the propeller shaft.

The IM (induction motor) electric motor/gearbox solution has a combined efficiency of 94.5%, while the PM (permanent magnet) motor solution has an efficiency of 96%. In addition, battery integration was evaluated for the different options, which can increase efficiency by 2.5%. The electrical distribution system has losses from the generators of the gensets themselves, switchboards, voltage transformers, and drivers that lead to a combined efficiency of 93%. This was taken into consideration when calculating the fuel consumption for the various solutions. For the NoGAPS machinery configuration assessment, the 4S PM1 option was selected mainly due to its higher efficiency. Figure 10 provides the single-line diagram for the 4S PM1 configuration.



Figure 10: Single-line diagram for 4S PM1 configuration.



The 4S solution gives a high degree of design flexibility. The engines that power the propulsion also supply energy to all the other consumers on board and are connected by electrical wires only. For a ship with ammonia as fuel, it can be valuable to explore the possibilities in terms of placement of the ammonia-fueled engines to help achieve a safe design. This can be beneficial, since it enables the segregation of ammonia-consuming equipment, easy and efficient pipe routing, and ventilation. This gives overall more design freedom for the 4S solution than the 2S solution, where the ammonia-consuming equipment must be coupled to the propeller shaft directly. In the current design concept stage, we focused mostly on evaluating fuel consumption, since we see this as a major factor, and not so much on the placement of the generator sets.



Fuel consumption during loading, transit in laden, and ballast plus unloading were calculated. Table 3 provides the fuel consumption and CO<sub>2</sub> emissions associated with the different operations, and the total CO<sub>2</sub> emissions for a trans-Atlantic roundtrip voyage. During loading, MGO is assumed to be the fuel used in the small genset. Engine MGO consumption includes the fuel used as the secondary pilot fuel for the main engines and MGO consumed during diesel-only operation. The total CO<sub>2</sub> emissions only include onboard vessel tank-to-wake emissions.

Table 3: Expected fuel consumption and CO<sub>2</sub> emissions for roundtrip voyage (4S PM1).

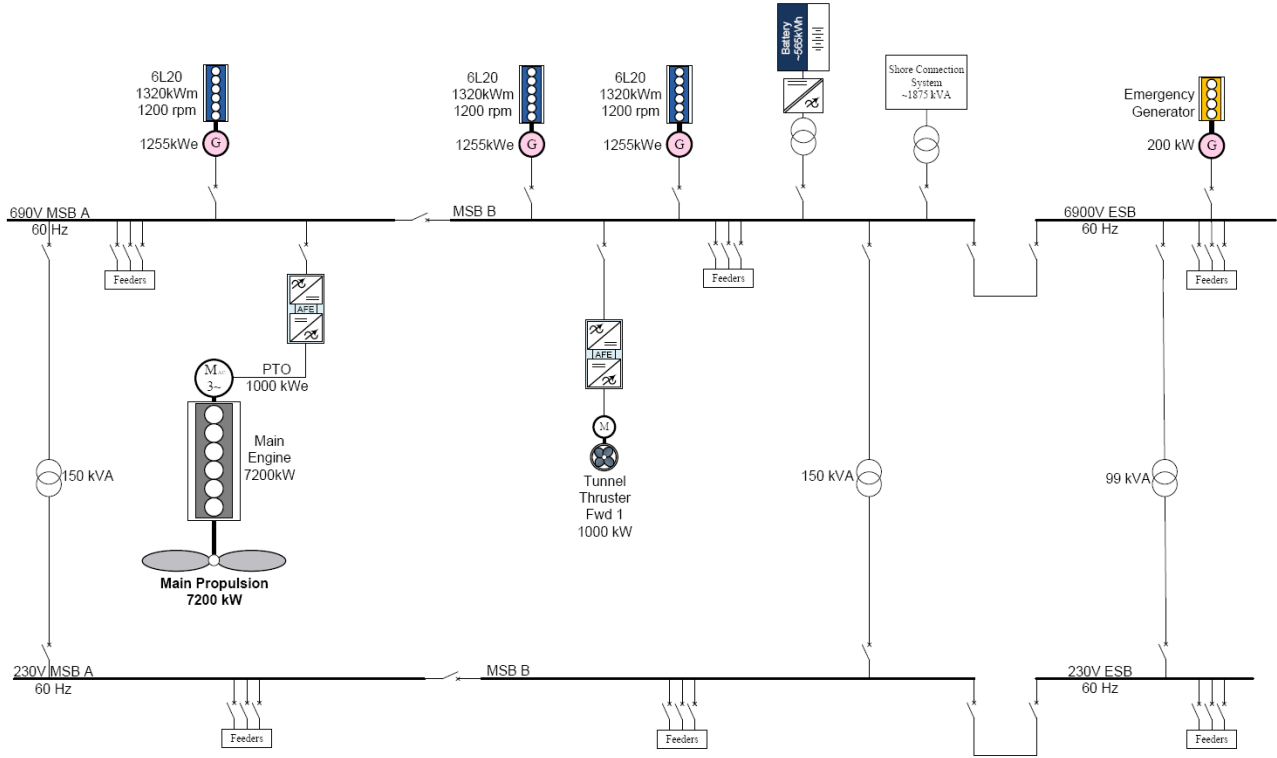
Operation	Engine MGO consumption [t]	Engine NH <sub>3</sub> consumption [t]	Total CO <sub>2</sub> emissions [t]
Cargo loading	5	0	11
Transit laden	99	906	316
Cargo unloading	8	0	14
Transit ballast	81	741	259
<b>Total</b>	<b>193</b>	<b>1,647</b>	<b>600</b>

### 7.3 Two-stroke machinery configuration

The ammonia 2S configuration consists of a single prime mover in the form of an ammonia-fueled two-stroke engine (7,200 kW). A shaft generator generates electricity via a variable frequency drive (VFD) using the main engine while the ship is at sea. In port, three diesel/biofuel-fueled auxiliary gensets supply electrical energy. The main driver for having diesel/biofuel-fueled gensets is to avoid having two different ammonia fuel systems, therefore reducing CapEx, improving safety, and reducing operational risk from having multiple ammonia consumers and all-new engine technologies onboard. Also, the auxiliary generator sets will only be used during port stays where the fuel consumption is low. Zero-emission operation can be achieved by using biofuel for the auxiliary gensets and as the secondary pilot fuel for the main engine. It is also possible to use the shore power connection for the power needed in port, if available. Figure 11 provides the single-line diagram for the 2S configuration.



Figure 11: Single-line diagram for 2S machinery configuration.



We have included a shaft generator for generating electrical energy on board during transit. The decision is based on the emission reduction benefits with diesel/ biofuel auxiliary gensets selected. Our evaluation of the economics of investing in a shaft generator based on fuel savings and maintenance costs concluded that the payback time would be over five years.

Fuel consumption during loading, transit in laden, and ballast plus unloading were calculated. Table 4 provides the fuel consumption and CO<sub>2</sub> emissions associated with the different operations and the total CO<sub>2</sub> emissions for a trans-Atlantic roundtrip voyage. During loading, MGO is assumed to be the fuel used in the small genset. Engine MGO consumption includes the fuel used as the secondary pilot fuel for the main engines and MGO consumed during diesel-only operation. The total CO<sub>2</sub> emissions only include onboard vessel tank-to-wake emissions.

Table 4: Expected fuel consumption and CO<sub>2</sub> emissions for roundtrip voyage (2S).

Operation	Engine MGO consumption [t]	Engine NH <sub>3</sub> consumption [t]	Total CO <sub>2</sub> emissions [t]
Cargo loading	6	0	11
Transit laden	29	858	94
Cargo unloading	9	0	16
Transit ballast	27	688	88
<b>Total</b>	<b>71</b>	<b>1,546</b>	<b>209</b>



## 7.4 Assessment summary

The assessment of machinery configurations followed the same methodology as with the accommodation location by evaluating cost, performance, safety, commercial availability, and design complexity. A summary of our assessment is provided in Figure 12. Fuel consumption and associated operational expenditure (OpEx) were the main priorities when assessing the two options.

Cost can be divided into CapEx and OpEx. CapEx was not a major driver as it did not vary significantly for the different machinery configurations, and there is so much uncertainty around the costs of ammonia-related equipment. It is expected that the most significant

additional costs with ammonia as a fuel will be related to fuel tanks, fuel treatment and supply systems, safety-related systems, and installation costs (piping, ventilation, etc.), not the engines themselves.

For OpEx calculations, we focused on fuel consumption. This is because available information on other OpEx aspects of using ammonia fuel, such as maintenance requirements, is limited or unknown. Table 5 shows the fuel consumption and estimated fuel cost on a projected trans-Atlantic roundtrip voyage at 15 knots for the 2S and 4S-PM1 machinery configurations. This trip includes one day for loading cargo, a laden voyage at 15 knots, one day for discharging operations, and a ballast voyage at 15 knots. A total of 35.4 days is assumed, meaning the ship can make around 10 round trips per year.

Table 5: Expected fuel consumption and cost summary (2S and 4S-PM1).

Round trip	NH <sub>3</sub> [t]	MGO [t] (pilot and auxiliary)	Fuel Cost [\$] (\$1500/t NH <sub>3</sub> , \$750/t MGO)
2S	1545	65	2,366,000
4S - PM1	1647	187	2,611,000
Difference	102	122	245,000

A large part of vessel operations is transit in laden and ballast condition. The 2S configuration offers lower fuel consumption, CO<sub>2</sub> emissions, and fuel costs throughout most vessel operations than the 4S configurations. The ammonia consumption does not differ much between the configurations. There is a thermal efficiency difference between the two- and four-stroke engines and, given the calorific difference between MGO and ammonia, most of the efficiency difference is due to the difference in pilot fuel consumption. This also translates to higher CO<sub>2</sub> emissions in the case of 4S-based configurations if MGO is used for pilot fuel.

Table 6: Machinery configuration assessment summary.

Consideration		Two-stroke	Four-stroke
Cost		-	Higher fuel consumption
Performance	Cargo capacity	Longer engine room needed	Additional 2% (300m <sup>3</sup> ) cargo possible
	Emissions	-	Higher emissions from fossil-based secondary fuels
Safety & Operations	Ammonia consumers	One main engine	Two main engines
	System pressure	Higher (80 bar)	Lower (10 bar)
	Redundancy (take home)	One main engine	Multiple engines/motors
Commercial availability		Engine development on similar timelines	
Design complexity		Mechanical	Diesel-electric





One advantage of the 4S configurations is that less space is needed in the engine room due to shorter length requirements, increasing the cargo volume by 2% (300 m<sup>3</sup>) with a more compact engine room.

Safety and operations criteria were also considered for the machinery configuration selection. However, there were no significant differences that influenced the final decision. We are confident that both arrangements can be developed to achieve safe operations. The 4S configurations have a higher degree of redundancy, with two electric motors supplying the propulsion and three engines capable of providing power. High 2S reliability, as seen on existing engines in operation, is also assumed and expected for this design. With the 2S configuration, there is only one ammonia consumer versus two with the 4S configuration. With fewer consumers, there is a potential to reduce the risk of leakages or ruptures due to less piping and sources. System pressures should also be considered and addressed during the risk assessment and design, as the 2S configuration has a higher system pressure of 80 bar. The 4S configurations have a lower expected system pressure of 10 bar.

Both machinery configurations are following similar development timelines and are expected to be commercially available around the same time. Also, both power and propulsion concepts are well established and known by both designers and shipyards.

In summary, our assessment of the machinery configurations concluded with selecting the 2S option. This was mainly driven by lower fuel consumption and associated emissions. The 2S configuration also contributes to a simplified safety concept with a single ammonia-consumer onboard that maximizes the emission reduction potential of ammonia as a fuel.





# 08 Other design considerations

In addition to the two main design considerations for the feasibility phase, other design aspects were evaluated. The following sections provide a brief overview of these aspects, including our main conclusions and decisions to be carried over into the initial design phase.

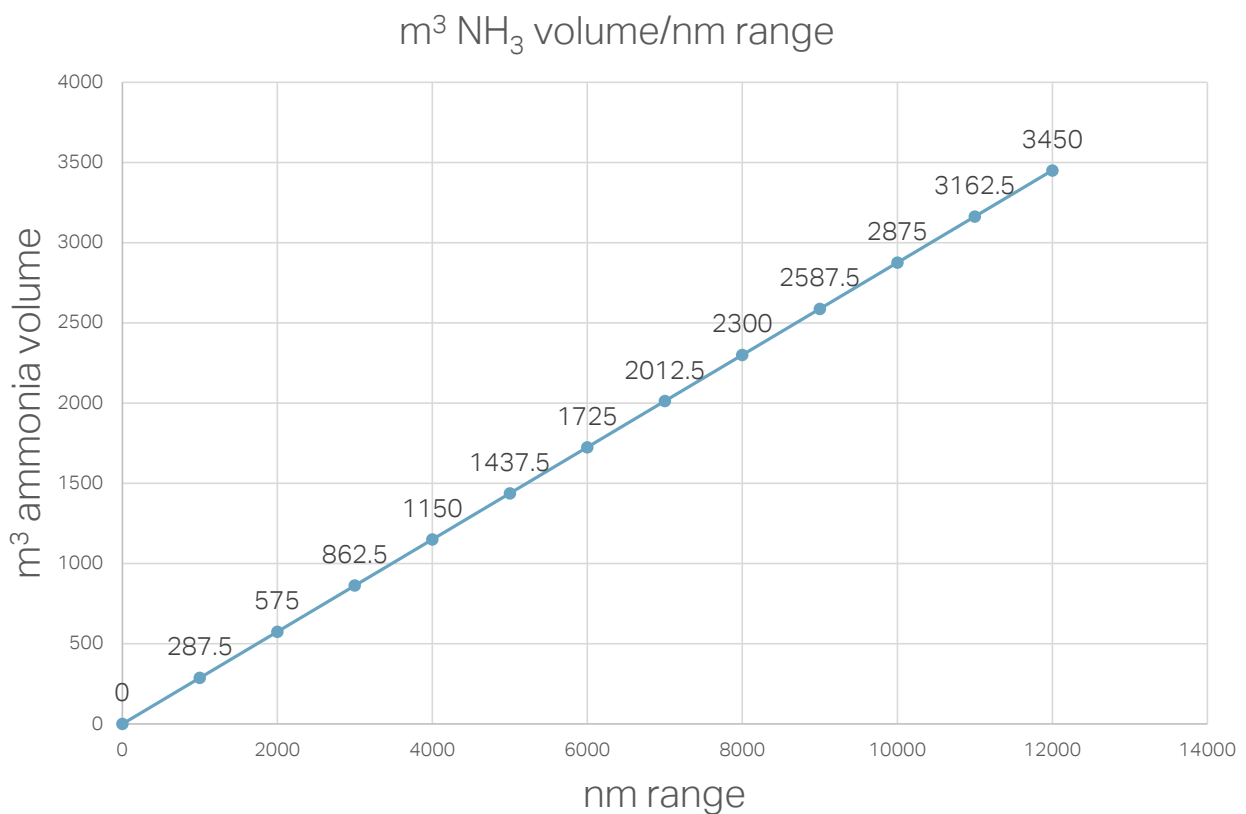
## 8.1 Fuel tank dimensioning

Ammonia fuel tanks were dimensioned based on the fuel consumption in the roundtrip model. Fuel tanks should allow for a roundtrip voyage from the Gulf of Mexico to Northwestern Europe (eastbound-laden, westbound-ballast) of approximately 12,000 nautical miles.

A four-day safety margin was also included. The fuel tank filling limit was specified by design requirements as 85%, with approximately 5% unpumpable. A 2% structural allowance was also included. Based on the calculation assumptions, the 2S configuration requires a net capacity of around 3,100 m<sup>3</sup> and a gross capacity of around 3,200 m<sup>3</sup>. A total fuel tank volume of 3,450 m<sup>3</sup> was set as a starting point in the design process.

The relationship between ammonia fuel tank volume and range is linear (see Figure 12). While the 3,450 m<sup>3</sup> capacity is the starting point in the design process, an objective for the initial design phase will be to optimize this capacity by evaluating the opportunities to reduce fuel consumption and the operational tradeoffs. Fewer or smaller tanks can also reduce CapEx and simplify the arrangement. Options to reduce ammonia fuel capacity include utilizing ammonia from the cargo during one leg of the roundtrip voyage, improving energy efficiency, or reducing service speed.

Figure 12: Ammonia tank volume based on range.



## 8.2 Bunkering capability

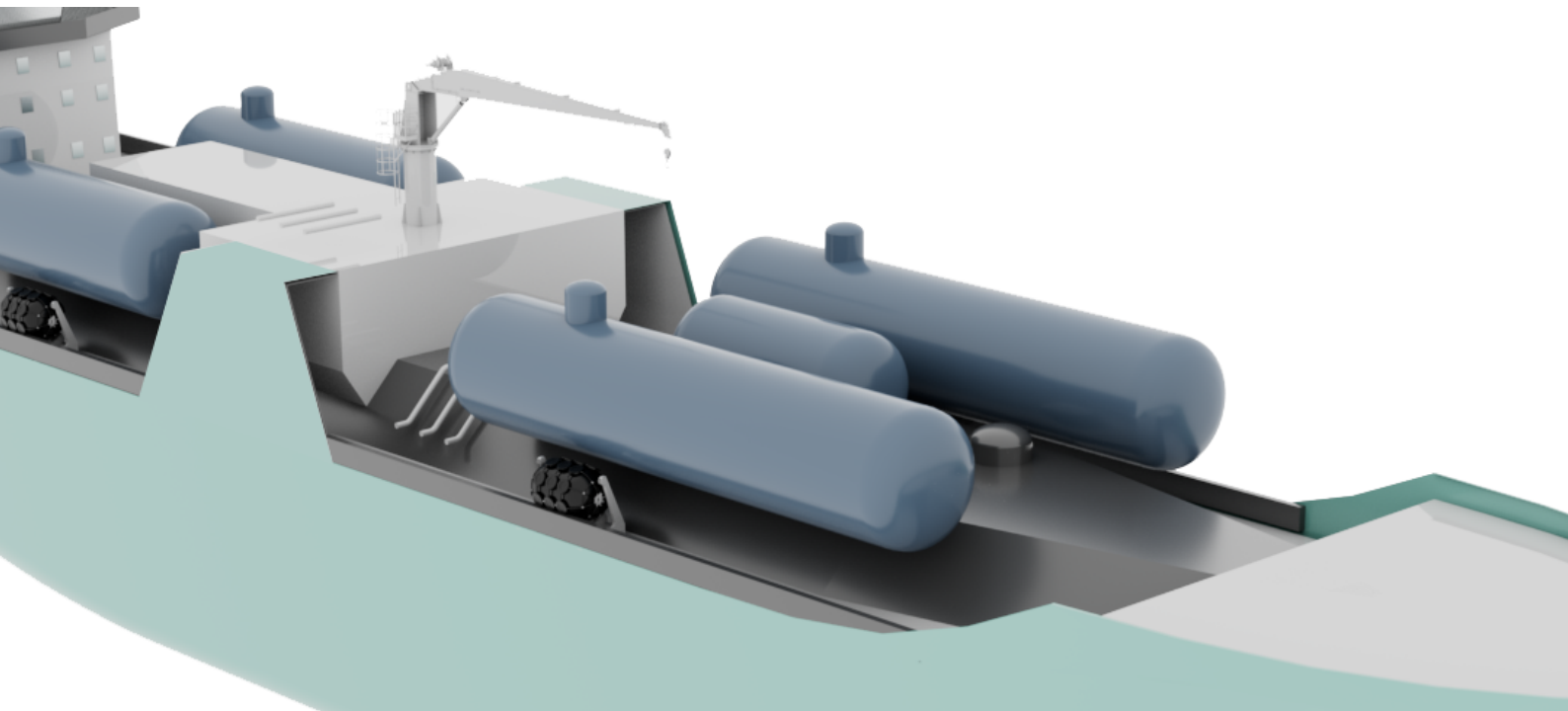
A potential additional feature for the ship is to be used as a bunkering vessel to bunker other ammonia-fueled ships. For that to be practical and possible, some additional features are required. The ship would require an additional elevated manifold. This has been modeled into the preliminary NoGAPS design on top of the cargo handling deck hoses. This is a practical location, within reach of the crane, and gives a good foundation as a working platform.

Proper mooring and fender arrangements must be in place to accommodate safe mooring alongside other ships that can be both smaller and larger. Two davit-launched Yokohama fenders have been modeled in the ship design, while additional mooring equipment (bollards, chocks, etc.) have not been investigated at this stage. The elevated mezzanine deck and probabilistic approach to placement of the deck fuel tanks enable the ship to have the tanks placed close to

the ship's sides and with a low center of gravity. That is beneficial for the stability characteristics of the ship, but leaves limited space for the davit and fender assembly. However, our initial study confirms that the fenders can be placed without compromising the original tank locations, while still leaving enough space to walk past them on the back side of the davit. Figure 14 provides a view of the bunkering capability considerations, including an elevated manifold and fenders.

In line with the NoGAPS reference vessel and due to the potential bunkering capability option, the design includes a bow thruster. This enables improved maneuverability in general and during bunkering operations. A bow thruster leads to additional resistance in transit in the range of 1-3%, with most computational fluid dynamics (CFD) simulation estimates in the 1.5-2.5% range, depending on the type of bow, chambering, and protection. Figure 13 shows the elevated manifold on top of the cargo handling deck hose and the fenders.

Figure 13: Bunkering capability considerations, including elevated manifold and fenders.



### 8.3 Stability

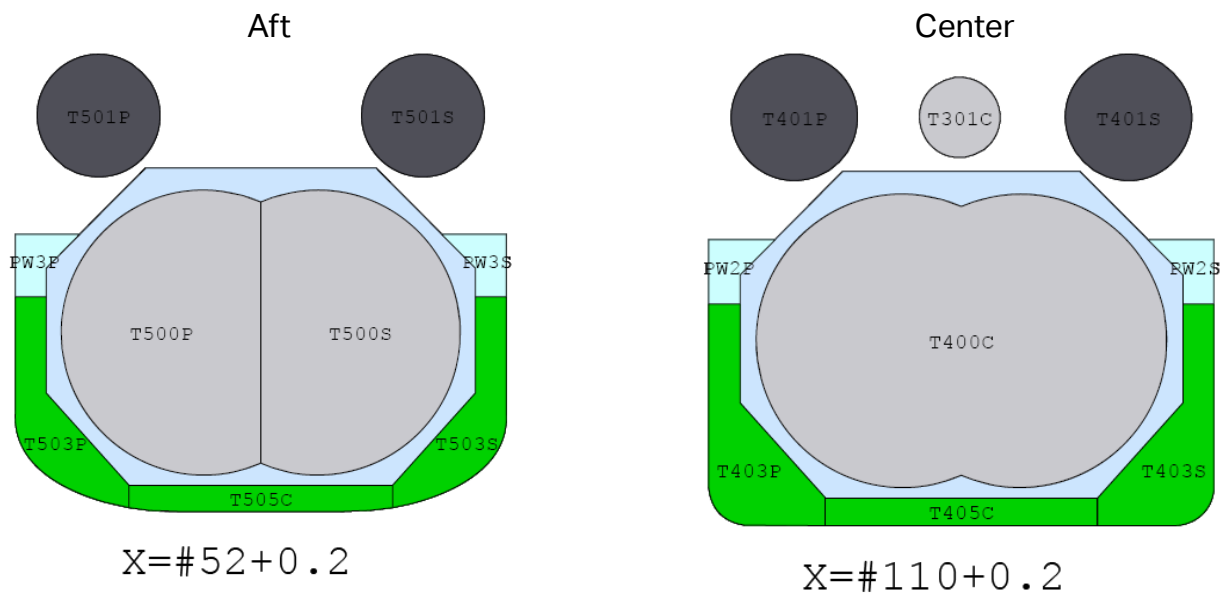
The vessel's stability, being one of the important safety aspects, must be verified during the feasibility phase to ensure that the vessel fulfills all regulatory and operational requirements. Preliminary stability calculations were completed for all four concepts, including the different accommodation locations and machinery configurations. Calculations include both intact and damage stability. The vessel type means it should comply with the International Code of Intact Stability (2008) and IGC Code, where requirements for damage stability are stated. The IGC Code requires deterministic damage stability to be applied. Thus, every operational loading condition must comply with the damage stability requirements.

For each design option, tank arrangements and preliminary lightship summaries were defined in NAPA, a stability software. The differences in the lightship of the vessel and its center of gravity (COG) are caused by the following factors:

- Location of the accommodation
- Location of the deck fuel tanks
- Size of the cargo tanks
- Different machinery alternatives/main propulsion equipment.

To properly compare all configurations and verify the influence of the arrangement and equipment, we limited stability verification to one hull form. The current concept assumes there are four ammonia fuel tanks on the canopy deck. The IGC Code does not provide guidance regarding the placement of the fuel tanks; however, direction from the IGF Code was used where direct or alternative requirements must be fulfilled. The direct approach requires tanks to be located no closer than beam/5 to the vessel's side, while the alternative approach is based on a probabilistic method. The present concept follows the latter approach, which provides more flexibility in the design and allows for a smaller distance to the side of the vessel, thus freeing space for cargo equipment in the centerline (CL) area. The probabilistic approach also enables a lower COG of the tanks by placing them on the side of the canopy deck. See Figure 14 for tank cross sections.

Figure 14: Cross section in aft and center cargo tank areas.



Considering the required ballast capacity in ballast conditions, side ballast tanks are extended to the tween deck, thus allowing two passageways between the tween and main decks, one at each side of the vessel, if needed.

The following loading conditions have been defined and verified during the analysis:

- Ballast departure
- Ballast intermediate
- Ballast arrival
- Departure, full cargo
- Departure, 80% of the cargo
- Departure, 50% of the cargo

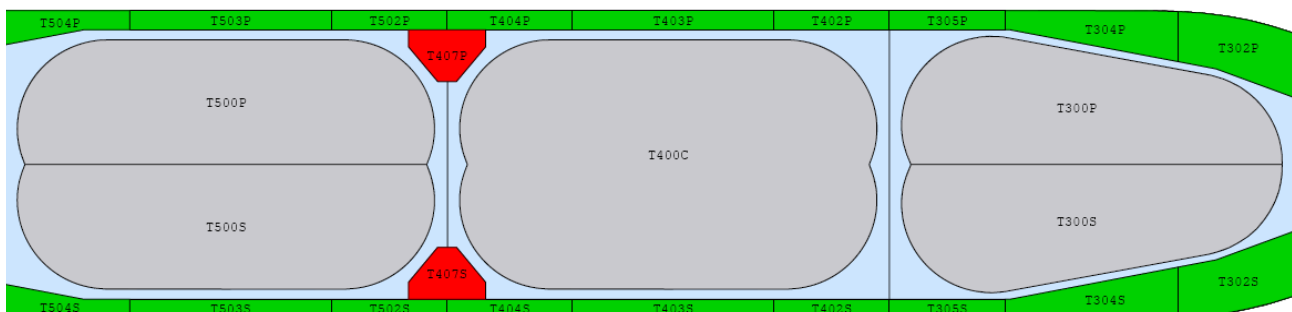
Due to the tank configuration, arrival conditions for cargo are considered similar or better than departure and, therefore, are not included. These must be checked during the next design phase for the selected configuration. All cargo departure loading conditions are verified without ballast.

Due to the vessel's bunkering capability option, departure condition with the maximum free surface correction from all cargo tanks has been defined. Each cargo tank is of bilobe type and features a longitudinal bulkhead between lobes as part of the required structure. In case this bulkhead is solid, the tank's free surface moment (FSM) is reduced by a factor of about four, which is beneficial for metacentric height

(GM) reduction in the intact condition. On the other hand, when damage occurs, it negatively influences the heel of the vessel and thus requires a higher GM. To avoid excessive stability margin to cope with the above, optimization of the FSM was applied by using a combination of solid and perforated bulkheads for all tanks (see Figure 15). In the optimal arrangement, the middle cargo tank features a CL bulkhead with openings, while aft and forward tanks are defined with a solid CL bulkhead.

All results are based on the preliminary lightship estimation and preliminary definition/absence of the secondary tanks with small influence. The selected concept will be evaluated with a more detailed arrangement in the next design phase. The final adjustment of the vessel's trim will be made by adjusting the hull form's longitudinal center of buoyancy (LCB) within the next design phase. Such an adjustment is expected to influence the vessel's resistance marginally.

Figure 15: Deck plan of cargo tanks.



## 09 Conclusions and next steps

The NoGAPS project has now concluded the feasibility phase, which consisted of defining the design objectives and requirements, assessing the two main design considerations of accommodation location and machinery configuration, and evaluating other design considerations such as fuel tank dimensioning, bunkering capability, and ship stability. The main design decisions include:

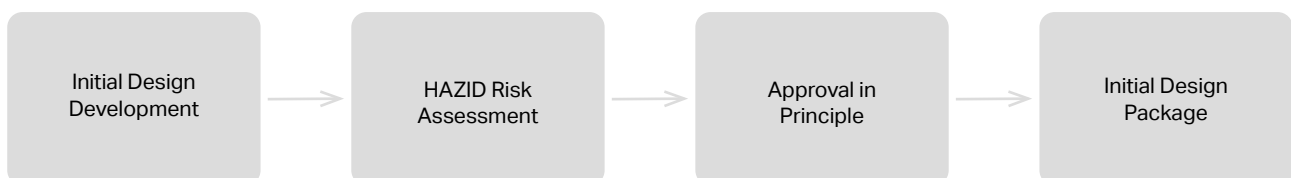
- Selection of aft accommodation
- Selection of two-stroke machinery configuration
- Further study preparation of the vessel for bunkering capability, including bow thruster
- The main engine will be only ammonia consumer with auxiliary engines and boiler, if needed, fueled by conventional or biofuels.

The approach and learnings from the NoGAPS project so far can be directly applied to ammonia-fueled gas carrier design development projects. General design, operational and safety considerations can also be evaluated for other vessel types; however, the applicability will vary based on the use of different regulations, operational models, design features and risk profiles.

The project will now enter the initial design phase to incorporate the key decisions and outcomes from the feasibility phase and increase the level of detail and analysis (see Figure 16).

The first major milestone within the initial design phase includes the kick-off of initial design development, including the completion of detailed design drawings. A HAZID qualitative risk assessment workshop will be completed to identify hazards, existing safeguards, and recommended further mitigation measures to be investigated. We will continue to maintain an ongoing dialogue with DMA and DNV, and submit design drawings and documentation, with the aim of obtaining an approval in principle from DNV. Finally, an initial design package will be prepared that can be used for submission to shipyards for official tenders.

Figure 16: Initial design phase main milestones.







Visit our website for more  
[www.zerocarbonshipping.com](http://www.zerocarbonshipping.com)

For more information on the project visit the Nordic Innovation [website](#).



**Mærsk Mc-Kinney Møller Center**  
for Zero Carbon Shipping